

Australian Light Vehicle Standards Rules 2015

as at 22 November 2019

As approved by the Transport and Infrastructure Council

Published by the Parliamentary Counsel's Committee

This is a consolidated version of the *Australian Light Vehicle Standards Rules 2015*. These Rules are a national model law and are intended to provide the basis for nationally consistent transport laws. These Rules do not, by themselves, have any legal effect.

	Page
Part 1 Preliminary	7
1 Name of rules	7
2 Object of Light Vehicle Standards	7
Part 2 Interpretation and application of the Light Vehicle Standards	8
3 Definitions	8
4 Meaning of <i>vehicle</i>	17
5 When restored vehicle is built	18
6 Measurement of width of vehicles	18
7 What is a road	18
8 What is a road-related area	18
9 Diagrams	19
10 Notes	19
11 Examples	19
12 Application to vehicles and combinations on roads and road-related areas	19
13 Vehicles to which the Light Vehicle Standards do not apply	19
14 Non-application of Light Vehicle Standards — exemption under other laws	20
15 Application of Light Vehicle Standards to vehicle complying with inconsistent ADR requirement	20
16 Application to vehicle subject of particular approval	21
17 Interpretation of certain second edition ADRs	21
18 References to adopted standards	22
19 Compliance with particular adopted standards	22
20 Compliance with requirement to have particular equipment	22
Part 3 Australian Design Rules	24
Division 1 Compliance with ADRs	25
21 Second edition ADRs	25
22 Third edition ADRs	25
Division 2 Exemptions from compliance with ADRs	28
23 Vehicles that are not road vehicles	28
24 Vehicles subject to particular approvals	28
25 Partial exemption for personally imported vehicles	29
Part 4 General safety requirements	31
Division 1 All vehicles	31
26 Steering	31
27 Turning ability	31
28 Ability to travel backwards and forwards	31
29 Protrusions	32

Contents

30	Driver's view and vehicle controls	32
31	Seating	32
32	Mudguards	32
33	Horns, alarms etc.	33
34	Rear vision mirrors	33
35	Rear vision mirrors — surfaces	34
36	Additional rear vision mirrors and surfaces	34
37	Automatic transmission	35
38	Diesel engines	35
39	Bonnet securing devices	35
40	Electrical wiring, components, connections and installations	35
41	Television receivers and visual display units	36
42	Requirement for windscreen to be fitted	36
43	Windscreens and windows	36
44	Window tinting	37
45	Windscreen wipers and washers	38
46	Wheels and tyres — size and capacity	39
47	Pneumatic tyres for particular vehicles	39
48	Pneumatic tyres — carcass construction	40
49	Tyres — defects	40
50	Tyres — manufacturer's rating	40
51	Retreads	41
52	Tyre tread	41
Division 2	Additional requirements for motor bikes	43
53	Steering gear and handlebars	43
54	Foot rests	43
55	Chain guards	44
Part 5	Vehicle marking	45
56	Engine and vehicle identification numbers	45
57	White or silver band on certain vehicles	45
Part 6	Vehicle configuration and dimensions	46
Division 1	Axles	46
58	Axle configuration	46
59	Retractable axles	47
Division 2	Dimension requirements	48
60	Meaning of <i>rear overhang</i> and <i>rear overhang line</i>	48
61	Length of single motor vehicles	49
62	Length of single trailers	49
63	Length of combinations	50
64	Rear overhang	50
65	Length — trailer drawbars	50
66	Width	51
67	Height	51

Contents

68	Ground clearance	51
Part 7	Lights and reflectors	53
Division 1	Application of particular requirements	53
69	Part does not apply to particular vehicles	53
70	Particular requirements apply only at night	53
Division 2	General requirements for lights	54
71	Prevention of glare	54
72	Pairs of lights	54
Division 3	Headlights	55
73	Headlights to be fitted to vehicles	55
74	How headlights are to be fitted	56
75	How single headlights are to be fitted	56
77	Performance of headlights	57
78	Effective range of headlights	57
79	Changing headlights from high-beam to low-beam position	57
Division 4	Parking lights	58
80	Parking lights	58
Division 5	Daytime running lights	60
81	Daytime running lights	60
Division 6	Tail lights	61
82	Tail lights generally	61
83	Pattern of fitting tail lights	61
84	Performance of tail lights	62
85	Wiring of tail lights	62
Division 7	Number plate lights	63
86	Number plate lights	63
Division 8	Clearance lights	64
87	Front clearance lights	64
88	External cabin lights	64
89	Rear clearance lights	64
Division 9	Side marker lights	66
90	Vehicles needing side marker lights	66
91	Location of side marker lights	66
92	Performance of side marker lights	67
93	Side marker lights and rear clearance lights	67
Division 10	Brake lights	68
94	Fitting brake lights	68
95	Performance and operation of brake lights	69

Contents

Division 11	Reversing lights	70
96	Reversing lights	70
Division 12	Direction indicator lights	71
97	Direction indicator lights on motor vehicles	71
98	Direction indicator lights on trailers	71
99	Location of direction indicator lights	71
100	Operation and visibility of direction indicator lights	72
Division 13	Fog lights	74
101	Front fog lights	74
102	Rear fog lights	74
Division 14	Interior lights	76
103	Interior lights	76
Division 15	Reflectors generally	77
104	General requirements for reflectors	77
Division 16	Rear reflectors	78
105	Rear reflectors	78
Division 17	Side reflectors	79
106	Compulsory side reflectors on pole-type trailers	79
107	Optional side reflectors	79
Division 18	Front reflectors	80
108	Compulsory front reflectors on particular trailers	80
109	Optional front reflectors	80
Division 19	Warning lights and signs on buses carrying children	81
110	Application of Division 19	81
111	Fitting of warning lights and signs	81
112	Operation and performance of warning lights	81
113	Specifications for warning signs	82
Division 20	Other lights, reflectors, rear marking plates or signals	84
114	Other lights and reflectors	84
115	Rear marking plates and conspicuity markings	85
116	Signalling devices	86
117	Mechanical signalling devices	86
118	Turn signals	86
Part 8	Braking systems	88
Division 1	Brake requirements for all vehicles	88
119	Components of a braking system	88
120	Provision for wear	88
121	Supply of air or vacuum to brakes	88

Contents

122	Performance of braking systems	89
Division 2	Motor vehicle braking systems	91
123	What braking system a motor vehicle must have	91
124	Operation of brakes on motor vehicles	92
125	Air or vacuum brakes on motor vehicles	92
Division 3	Trailer braking systems	93
126	What brakes a trailer must have	93
127	Operation of brakes on trailers	93
128	Air or vacuum brakes on trailers	93
Part 9	Control of emissions	94
Division 1	Crank case gases and exhaust emissions	94
129	Crank case gases	94
130	Visible emissions – vehicles with internal combustion engines	94
131	Exhaust emissions – diesel-powered vehicles	94
132	Requirements of DT 80 test cycle	96
133	Test procedure	99
Division 2	Exhaust systems	101
134	Exhaust systems	101
Division 3	Noise emissions	102
Subdivision 1	General	102
135	Measurement of stationary noise levels	102
136	Meaning of “certified to ADR83/00”	102
137	Silencing device for exhaust systems	102
Subdivision 2	Noise levels applying to vehicles certified prior to the application of ADR 83/00	103
138	Application of rules in Subdivision 2	103
139	Stationary noise levels — car-type vehicles and motor bikes and motor trikes	103
140	Stationary noise levels — other vehicles with spark ignition engines	103
141	Stationary noise levels — other vehicles with diesel engines	104
Subdivision 3	Noise levels applying to vehicles certified to ADR 83/00	105
142	Stationary noise levels	105
Part 10	Alternative fuel systems	106
143	LPG-powered vehicles	106
144	Vehicles powered by natural gas	106
144A	Hydrogen-powered vehicles	106
144B	Electric-powered vehicles	108
Part 11	Mechanical connections between vehicles	110
145	General coupling requirements	110
146	Drawbar couplings	110

Part 1 Preliminary

Note The *Australian Light Vehicle Standards Rules 2015* set standards that vehicles must comply with to be driven on roads and road-related areas.

The ADRs (Australian Design Rules) are rules for designing and building vehicles. Imported vehicles must also comply with the ADRs.

The Light Vehicle Standards require a vehicle that is subject to an ADR when built or imported to continue to comply with the ADR.

The Light Vehicle Standards also apply certain other standards (adopted standards) that are intended to complement the ADRs.

The ADRs do not cover:

- vehicles built before 1969
- combinations of vehicles of any age
- every safety feature for vehicles built between 1969 and 1988.

These matters are covered by the Light Vehicle Standards.

In most cases, if a vehicle complies with the Light Vehicle Standards, it is suitable for road use.

1 Name of rules

These rules are the *Australian Light Vehicle Standards Rules 2015* (the *Light Vehicle Standards*).

2 Object of Light Vehicle Standards

- (1) The object of the Light Vehicle Standards is to set uniform Australian standards about the construction and performance of motor vehicles, trailers and combinations that are light vehicles.
- (2) The standards are intended:
 - (a) to promote, throughout the life of those motor vehicles, trailers and combinations, their safe use and efficiency and the protection of the environment; and
 - (b) to reduce the cost of transport administration.

Part 2 Interpretation and application of the Light Vehicle Standards

3 Definitions

(1) In these rules:

adopted standard means a standard, except an ADR, that is adopted, applied or incorporated by the Light Vehicle Standards.

Example Rule 51 (2) (c) applies Australian Standard AS 1973-1976 *Retreaded Pneumatic Passenger Car and Light Truck Tyre*.

ADR means:

- (a) a third edition ADR; or
- (b) a second edition ADR.

ADR (Definitions and Vehicle Categories) means the third edition ADR titled ‘Vehicle Standard (Australian Design Rule – Definitions and Vehicle Categories) 2005’ made under the Motor Vehicle Standards Act.

air brake means an air-operated or air-assisted brake.

Air Services Act means the *Air Services Act 1995* (Cwlth).

Airservices Australia see the Air Services Act, section 7.

Airservices Australia vehicle means a vehicle driven by any of the following persons in the course of the person’s duty to Airservices Australia:

- (a) the Chief Executive Officer of Airservices Australia appointed under the Air Services Act, section 34;
- (b) a person appointed to act as Chief Executive Officer of Airservices Australia under the Air Services Act, section 41;
- (c) a person employed under the Air Services Act, section 42;
- (d) a person engaged as a consultant under the Air Services Act, section 43.

air storage tank, of a vehicle, means a tank fitted to the vehicle for storing compressed air.

ATM (aggregate trailer mass), of a trailer, means the total maximum mass of the trailer, as stated by the manufacturer, together with the trailer’s load and the mass imposed on the towing vehicle by the trailer when the towing vehicle and trailer are on a horizontal surface.

Australian Border Force see the *Australian Border Force Act 2015* (Cwlth), section 4(1).

Australian Border Force vehicle means a vehicle driven by an Immigration and Border Protection worker in the course of the worker's duty to the Australian Border Force.

Australian Standard means a standard approved for publication by Standards Australia.

Note Copies of Australian Standards are available for purchase from Standards Australia at <www.standards.org.au>.

axle means 1 or more shafts, positioned in a line across a vehicle, on which 1 or more wheels intended to support the vehicle turn.

axle group means a single, tandem or tri-axle group.

braking system, of a vehicle, means all the brakes of the vehicle and all the components of the mechanisms by which they are operated.

British Standard means a standard approved for publication on behalf of the British Standards Institution.

Note Copies of British Standards are available for purchase from Standards Australia at <www.standards.org.au>.

British Standards Institution means the institution of that name established under royal charter in the United Kingdom.

bus means a motor vehicle built mainly to carry people that seats over 9 adults (including the driver).

car means a motor vehicle built mainly to carry people that:

- (a) seats not over 9 adults (including the driver); and
- (b) has a body commonly known as a sedan, station wagon, coupe, convertible, or roadster; and
- (c) has 4 or more wheels.

centre line, of an axle, means:

- (a) for an axle consisting of 1 shaft — a line parallel to the length of the axle and passing through the centre of the axle; or
- (b) for an axle consisting of 2 shafts—a line in the vertical plane passing through:
 - (i) the centre of both shafts; and
 - (ii) the centres of the wheels on the shafts.

centre line, of an axle group, means:

- (a) if the group consists of 2 axles, one of which is fitted with twice the number of tyres as the other axle — a vertical line located one-third of the way from the centre line of the axle with more tyres towards the centre line of the axle with fewer tyres; and

[r 3]

- (b) in any other case — a line located midway between the centre lines of the outermost axles of the group.

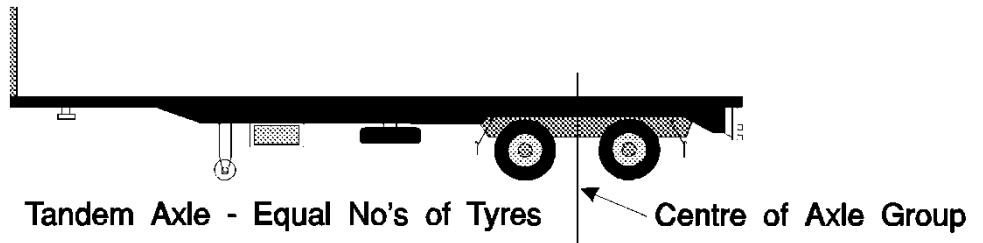

Centre line of a tandem axle group fitted with an equal number of tyres on each axle

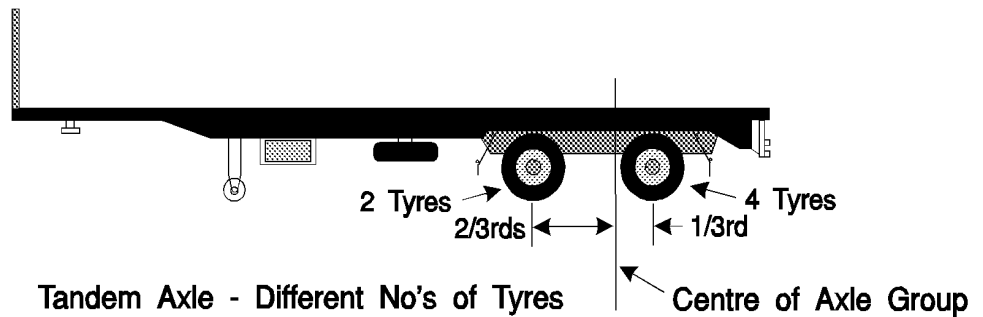

Centre line of a tandem axle group fitted with a different number of tyres on each axle

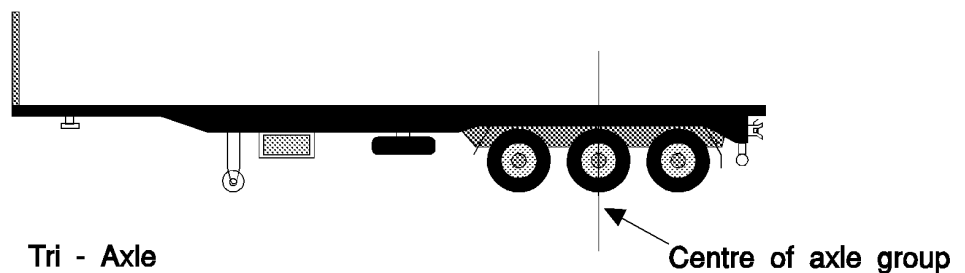

Centre line of a tri-axle group

combination means a group of vehicles consisting of a motor vehicle connected to 1 or more vehicles.

[r 3]

converter dolly means a trailer with 1 axle group or single axle, and a fifth wheel coupling, designed to convert a semi-trailer into a dog trailer.

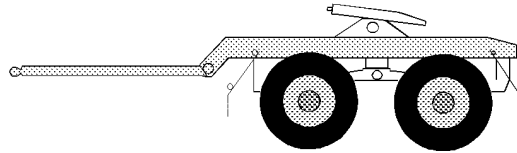

Converter dolly

daylight means the period in a day from sunrise to sunset.

diesel engine means an engine that works on the compression-ignition principle, commonly known as a diesel engine.

dog trailer means a trailer (including a trailer consisting of a semi-trailer and converter dolly) with:

- (a) 1 axle group or single axle at the front that is steered by connection to the towing vehicle by a drawbar; and
- (b) 1 axle group or single axle at the rear.

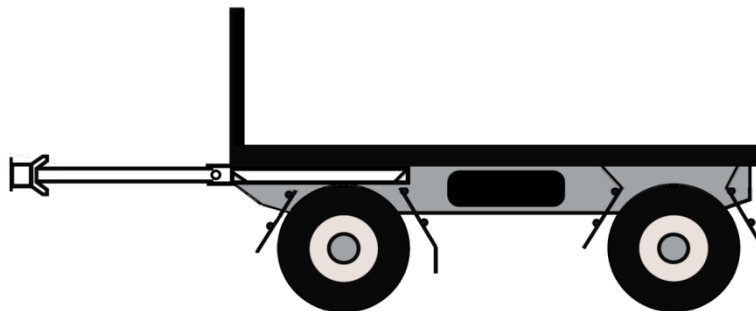

Dog trailer

drawbar means a part of a trailer (except a semi-trailer) connecting the trailer body to a coupling for towing purposes

drive includes be in control of.

driver, of a vehicle, means the person driving the vehicle.

emergency brake means a brake designed to be used if a service brake fails.

emergency vehicle means a vehicle that is an emergency vehicle under a law of this jurisdiction.

exempt vehicle means:

- (a) an Airservices Australia vehicle; or

[r 3]

- (b) an Australian Border Force vehicle; or
- (c) an emergency vehicle; or
- (d) a police vehicle; or
- (e) a transport enforcement vehicle.

fifth wheel coupling means a device, except the upper rotating element and the kingpin (which are parts of a semi-trailer), used with a prime mover, semi-trailer, or converter dolly, to allow quick coupling and uncoupling and to provide for articulation.

front fog light means a light used to improve the illumination of the road in case of fog, snowfall, heavy rain or a dust storm.

GTM (gross trailer mass) means the mass transmitted to the ground by the axles of a trailer when the trailer is loaded to its GVM and connected to a towing vehicle.

GVM (gross vehicle mass), for a vehicle, means the maximum loaded mass of the vehicle:

- (a) as stated on the RAV for that vehicle; or
- (b) if it is not stated on the RAV — as stated by the vehicle's manufacturer on an identification plate on the vehicle (that is, the plate of the kind referred to in section 10A of the Motor Vehicle Standards Act, affixed or taken to be affixed to the vehicle, in force immediately before the repeal of that Act); or
- (c) if it is not stated on the RAV or on the vehicle's identification plate, or if there is a specification on an identification plate on the vehicle but the specification is not appropriate because the vehicle has been modified — as certified by the vehicle registration authority.

Heavy Vehicle National Law means the Heavy Vehicle National Law set out in the Schedule to the *Heavy Vehicle National Law Act 2012* of Queensland.

high-beam, for a headlight or front fog light fitted to a vehicle, means that the light is built or adjusted so, when the vehicle is standing on level ground, the top of the main beam of light projected is above the low beam position.

Immigration and Border Protection worker see the *Australian Border Force Act 2015* (Cwlth), section 4(1).

left, for a vehicle, means to the left of the centre of the vehicle when viewed by a person in the vehicle who is facing to the front of the vehicle.

light vehicle means a vehicle:

- (a) if the vehicle is a trailer — with an ATM of 4.5t or less; or

[r 3]

(b) otherwise — with a GVM of 4.5t or less.

low-beam, for a headlight or front fog light fitted to a vehicle, means that the light is built or adjusted so, when the vehicle is standing on level ground, the top of the main beam of light projected is:

- (a) not higher than the centre of the headlight or fog light, when measured 8 metres in front of the vehicle; and
- (b) not over 1 metre higher than the level where the motor vehicle is standing, when measured 25 metres in front of the vehicle.

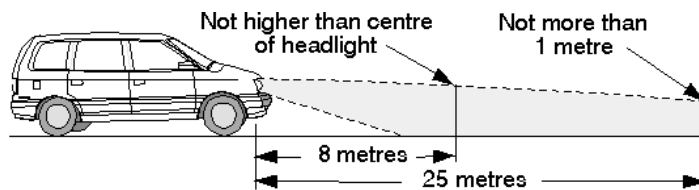

A headlight in the low-beam position

moped means a motor bike or motor trike with an engine cylinder capacity of not over 50 millilitres and a maximum speed of not over 50 kilometres an hour.

motor bike means a motor vehicle with 2 wheels, and includes a 2-wheeled motor vehicle with a sidecar attached to it that is supported by a third wheel.

motor trike means a motor vehicle with 3 wheels, but does not include a 2-wheeled motor vehicle with a sidecar attached to it that is supported by a third wheel.

motor vehicle means a vehicle built to be propelled by a motor that forms part of the vehicle.

Motor Vehicle Standards Act means the repealed *Motor Vehicle Standards Act 1989* (Cwlth) as in force before its repeal.

mudguard means a fitting or device, with or without a mudflap, that is built and fitted to a vehicle in a way that will, as far as practicable, catch or deflect downwards any mud, stone, water, or other substance, thrown up by the rotation of the wheel of the vehicle for which the fitting or device is fitted.

nearer side of the vehicle, in relation to a light or reflector fitted to a vehicle, means the side of the vehicle that is closest to where the light or reflector is fitted.

parking brake, of a vehicle, means the brake usually used to keep the vehicle stationary while the vehicle is parked.

point of articulation means:

- (a) the axis of a kingpin for a fifth wheel; or

[r 3]

- (b) the vertical axis of rotation of a fifth wheel coupling; or
- (c) the vertical axis of rotation of a turntable assembly; or
- (d) the vertical axis of rotation of the front axle group, or single axle, of a dog trailer; or
- (e) the coupling pivot point of a semi-trailer.

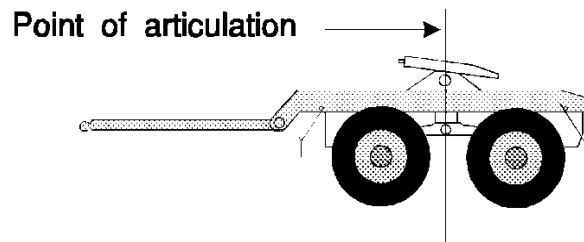

Point of articulation — fifth wheel coupling on a converter dolly (forming the front axle group of a dog trailer)

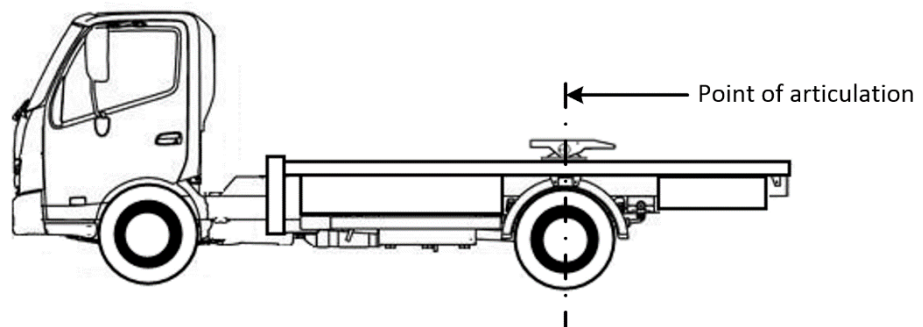

Point of articulation — fifth wheel on a prime mover

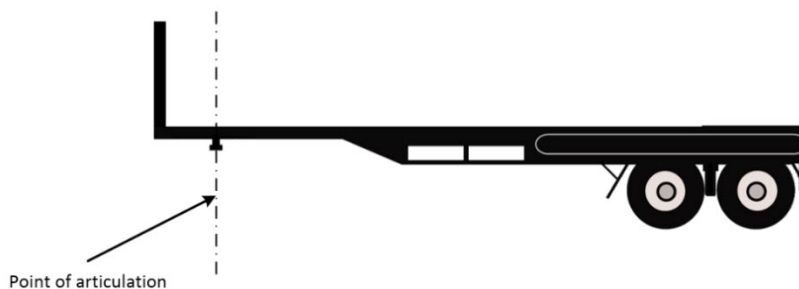

Point of articulation — kingpin for fifth wheel

[r 3]

pole-type trailer means a trailer that:

- (a) is attached to a towing vehicle by a pole, or an attachment fitted to the pole; and
- (b) is ordinarily used for transporting loads, such as logs, pipes, structural members, or other long objects, that can generally support themselves like beams between supports.

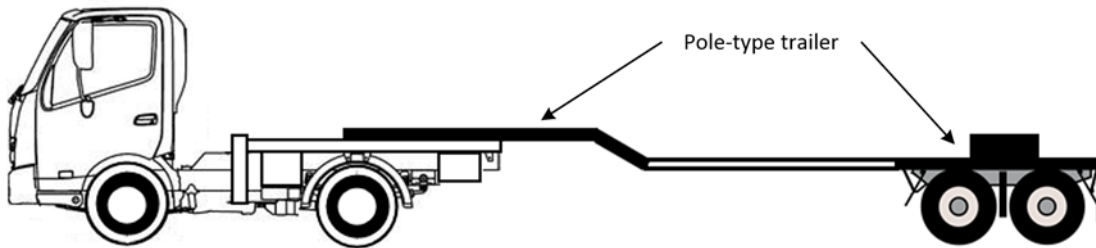

Pole-type trailer

police vehicle means a vehicle driven by a police officer in the course of his or her duty.

prime mover means a motor vehicle built to tow a semi-trailer.

RAV means the Register of Approved Vehicles kept under section 14 (1) of the Road Vehicle Standards Act.

rear overhang, for the purposes of Part 6, Division 2, see rule 60.

rear overhang line, for the purposes of Part 6, Division 2, see rule 60.

right, for a vehicle, means to the right of the centre of the vehicle when viewed by a person in the vehicle who is facing to the front of the vehicle.

road see rule 7.

Road Vehicle Standards Act means the *Road Vehicle Standards Act 2018* (Cwlth).

road-related area see rule 8.

second edition ADR means an Australian Design Rule incorporated in the document described as the *Australian Design Rules for Motor Vehicle Safety, Second Edition* originally published by the then Commonwealth Department of Transport.

semi-trailer means a trailer (including a pole-type trailer) that has:

- (a) 1 axle group or single axle to the rear; and
- (b) a means of attachment to a prime mover that results in some of the load being imposed on the prime mover.

service brake, for a vehicle, means the brake normally used to decelerate the vehicle.

side marker light means a light fitted to the side of a vehicle indicating the presence and length of the vehicle when viewed on that side.

single axle means an axle not forming part of an axle group.

single axle group means a group of at least 2 axles in which the horizontal distance between the centre lines of the outermost axles is less than 1 metre.

Standards Australia means Standards Australia Limited ACN 087 326 690, or any body to which Standards Australia Limited is a successor in law or that is a successor in law to Standards Australia Limited.

street rod vehicle means a vehicle that:

- (a) has been modified for safe road use; and
- (b) either:
 - (i) has a body and frame that were built before 1949; or
 - (ii) is a replica of a vehicle, the body and frame of which were built before 1949.

tandem axle group means a group of at least 2 axles in which the horizontal distance between the centre lines of the outermost axles is at least 1 metre, but not over 2 metres.

third edition ADR means:

- (a) a national standard under the Motor Vehicle Standards Act as in force from time to time before the repeal of that Act; or
- (b) a national road vehicle standard under section 12 of the Road Vehicle Standards Act as in force from time to time.

towing vehicle, for a trailer, means the vehicle towing the trailer.

trailer means a vehicle that is built to be towed, or is towed, by a motor vehicle, but does not include a motor vehicle that is being towed.

transport enforcement vehicle means:

- (a) a vehicle that is a transport enforcement vehicle under a law of this jurisdiction; or
- (b) a vehicle other than a police vehicle, that is driven by an authorised officer, within the meaning of the Heavy Vehicle National Law, in the course of his or her duty.

tri-axle group means a group of at least 3 axles in which the horizontal distance between the centre lines of the outermost axles is over 2 metres, but not over 3.2 metres.

[r 4]

turntable means a bearing built to carry vertical and horizontal loads, but that does not allow quick separation of its upper and lower rotating elements, and that is used to connect and allow articulation between:

- (a) a prime mover and semi-trailer; or
- (b) the steering axle or axle group of a dog trailer and the body of the trailer; or
- (c) a fifth wheel coupling and the vehicle to which it is mounted.

vacuum brakes means vacuum-operated or vacuum-assisted brakes.

vacuum storage tank, of a vehicle, means a tank fitted to the vehicle for storing air at low pressure.

vehicle see rule 4.

vehicle registration authority means the entity responsible for the registration of vehicles under a law of this jurisdiction.

warning light means a light fitted to a vehicle designed specifically to warn road users of the vehicle's presence on a road.

yellow includes amber.

- (2) The definitions in subrule (1) define certain words and expressions, and include signpost definitions to words and expressions defined elsewhere in the Light Vehicle Standards.

Note A signpost definition (e.g. **road-related area** see rule 8) is included in subrule (1) if the definition applies outside the rule defining the word or expression.

- (3) The definitions in subrule (1) are part of the Light Vehicle Standards.
- (4) A definition in the Light Vehicle Standards applies to each use of the word or expression in the Light Vehicle Standards, unless the contrary intention appears.
- (5) (Repealed)

4 Meaning of vehicle

- (1) For the purposes of the Light Vehicle Standards, a reference to a **vehicle** is taken to be a reference to a light vehicle.
- (2) To remove any doubt:
 - (a) a trailer is a **vehicle**; and
 - (b) a reference in the Light Vehicle Standards to a **vehicle** includes a reference to the equipment fitted to, or forming part of, the vehicle; and
 - (c) a reference in the Light Vehicle Standards to a vehicle is taken to be a reference to a single vehicle.

5 When restored vehicle is built

- (1) In this rule:

restored vehicle means a vehicle that is being, or has been, restored to the vehicle's manufacturer's specifications, so far as it is practicable to meet the specifications.

- (2) For the Light Vehicle Standards, a restored vehicle is taken to have been built when the vehicle was originally built and not when the vehicle was restored.

6 Measurement of width of vehicles

For the purposes of the Light Vehicle Standards, the width of a vehicle is measured disregarding any of the following devices:

- (a) an anti-skid device mounted on the wheels of the vehicle;
- (b) a central tyre inflation system fitted to the vehicle;
- (c) any side marker light fitted to the vehicle;
- (d) any mirror fitted to the vehicle;
- (e) any reflector fitted to the vehicle;
- (f) any signalling device fitted to the vehicle;
- (g) any tyre pressure gauge fitted to the vehicle;
- (h) any permanently fixed webbing assembly-type device, if the maximum distance across the body of the vehicle, including any part of the device, is not more than 2.55 metres.

Example of permanently fixed webbing assembly-type device A curtain-side device.

7 What is a road

A *road* is an area that is open to or used by the public and is developed for, or has as one of its main uses, the driving or riding of motor vehicles.

8 What is a road-related area

A *road-related area* is any of the following:

- (a) an area that divides a road;
- (b) a footpath or nature strip next to a road;
- (c) an area that is open to the public and is designated for use by cyclists or animals;
- (d) an area that is not a road and that is open to or used by the public for driving, riding or parking vehicles.

[r 9]

9 Diagrams

- (1) A diagram in the Light Vehicle Standards is part of the Light Vehicle Standards.
- (2) A diagram of something is an illustrative example of the thing, but does not represent the thing's dimensions or the dimensions of any part of the thing.

10 Notes

A note in the Light Vehicle Standards is explanatory and is not part of the Light Vehicle Standards.

11 Examples

- (1) An example (whether or not in the form of a diagram) in the Light Vehicle Standards is part of the Light Vehicle Standards.
- (2) If the Light Vehicle Standards includes an example of the operation of a provision of the Light Vehicle Standards:
 - (a) the example is not exhaustive; and
 - (b) the example does not limit, and may extend, the meaning of the provision; and
 - (c) the example and the provision are to be read in the context of each other and of the other provisions of the Light Vehicle Standards, but, if the example and the provision as so read are inconsistent, the provision prevails.

12 Application to vehicles and combinations on roads and road-related areas

The Light Vehicle Standards apply to motor vehicles, trailers and combinations on roads and road-related areas.

13 Vehicles to which the Light Vehicle Standards do not apply

- (1) In this rule:

heavy vehicle means a vehicle:

 - (a) if the vehicle is a trailer — with an ATM of more than 4.5t; or
 - (b) otherwise — with a GVM of more than 4.5t.
- (2) The Light Vehicle Standards do not apply to:
 - (a) a vehicle used only on a railway or tramway; or
 - (b) a vehicle designed to be controlled by a person walking next to it;
or

[r 14]

- (c) a vehicle propelled by a motor with a maximum power output of not over 200 watts; or
- (d) a power-assisted pedal cycle within the meaning of a national road vehicle standard under section 12 of the Road Vehicle Standards Act, as amended from time to time; or
- (e) any cycle that was previously a power-assisted pedal cycle within the meaning of a third edition ADR, but that is no longer a power-assisted pedal cycle because of a change to the way that concept is defined; or
- (f) a motorised wheelchair that cannot travel at over 10 kilometres an hour; or
- (g) a vehicle or combination that is being repaired, or is being tested in the course of being repaired, so it will comply with the Light Vehicle Standards; or
- (h) a vehicle or combination being driven or towed directly to a place where it is to be repaired so it will comply with the Light Vehicle Standards; or
- (i) a heavy vehicle.

Note With respect to paragraphs (d) and (e), power-assisted pedal cycle is defined in ADR (Definitions and Vehicle Categories). The definition includes vehicles referred to as pedalecs.

14 Non-application of Light Vehicle Standards — exemption under other laws

- (1) A provision of the Light Vehicle Standards does not apply to a vehicle or combination if the vehicle or combination is exempt from:
 - (a) the provision under another law of this jurisdiction; or
 - (b) the corresponding provision of the law of another jurisdiction.
- (2) However, the vehicle or combination is exempt only if all conditions of the exemption (if any) are being complied with.

Example An exemption allowing a greater dimension limit for a vehicle is subject to conditions about the route where, and times when, the vehicle is allowed to travel. A relevant provision of the Light Vehicle Standards does not apply to the vehicle only if the conditions are complied with.

15 Application of Light Vehicle Standards to vehicle complying with inconsistent ADR requirement

- (1) A requirement of Parts 4 to 10 does not apply to a vehicle if the requirement is inconsistent with a requirement of a second or third edition ADR that the vehicle complies with (regardless of whether or not the vehicle is required to comply with the ADR requirement).

[r 16]

- (2) Subrule (1) does not apply if the vehicle is not of the same class or type as the vehicles to which the ADR requirement applies.

Example As the second and third edition ADR do not apply to a vehicle built in 1968, the vehicle must comply with rule 121 (What braking system a motor vehicle must have). If the owner of that type of vehicle modified the brakes so that they did comply with the second edition ADR, any requirement in rule 121 in relation to the vehicle's brakes that was inconsistent with the second edition ADR would no longer apply to the vehicle.

However, if the modified brakes only comply with a rule of the second edition ADR that only applies to passenger cars, then rule 121 does apply, as subrule (1) of rule 15 would not apply as a result of subrule (2), because a vehicle is not a passenger car.

16 Application to vehicle subject of particular approval

A provision of Parts 4 to 10 of the Light Vehicle Standards does not apply to a vehicle if:

- (a) the vehicle does not comply with a requirement of an ADR applying to the vehicle; and
- (b) the provision of the Light Vehicle Standards corresponds to the requirement of the ADR; and
- (c) despite the non-compliance:
 - (i) before the repeal of the Motor Vehicle Standards Act an approval was given under section 10A (2) or (3) to place an identification plate on the vehicle; or
 - (ii) an approval is given under item 4 (2) or 6 (2) of Schedule 3 to the *Road Vehicle Standards (Consequential and Transitional Provisions) Act 2018* (Cwlth); or
 - (iii) the vehicle satisfied an entry pathway under section 15 (2) of the Road Vehicle Standards Act and the vehicle is entered on the RAV; and
- (d) the vehicle complies with the approval conditions (if any).

Note 1 Section 10A (2) of the Motor Vehicle Standards Act deals with vehicles that do not comply with an ADR, but the non-compliance is only minor and inconsequential.

Note 2 Section 10A (3) of the Motor Vehicle Standards Act deals with vehicles that do not comply with an ADR, and the non-compliance is not minor and inconsequential, but the vehicle will be safe to use if conditions are complied with.

17 Interpretation of certain second edition ADRs

The words 'left' and 'right' in the following second edition ADRs have the opposite meaning in the application of the ADRs, in accordance

[r 18]

with the Light Vehicle Standards, to a motor vehicle with a left-hand drive:

- ADR 8 Safety Glass
- ADR 12 Glare Reduction in Field of View
- ADR 14 Rear Vision Mirrors
- ADR 16 Windscreen Wipers and Washers
- ADRs 18 and 18A Location and Visibility of Instruments
- ADRs 35 and 35A Commercial Vehicle Braking Systems.

18 References to adopted standards

Unless the contrary intention appears, a reference in a rule or subrule to an adopted standard is a reference to the adopted standard as in force when the rule or subrule commenced.

19 Compliance with particular adopted standards

- (1) This rule applies if:
 - (a) a provision of these rules requires a vehicle, or a component of a vehicle, to comply with an adopted standard (the *replaced standard*); and
 - (b) the adopted standard has been replaced by a later adopted standard (the *later standard*).
- (2) The vehicle or component is taken to comply with the replaced standard if the vehicle or component complies with the later standard.

Example A vehicle is taken to comply with the replaced standard AS 1973-1976 *Retreaded Pneumatic Passenger Car Tyres* if the vehicle complies with the later standard AS 1973-1993 *Pneumatic tyres - Passenger car, light truck, and truck/bus - Retreading and repair processes*.

20 Compliance with requirement to have particular equipment

- (1) A vehicle is taken to have equipment mentioned in the Light Vehicle Standards only if the equipment is:
 - (a) in working order; and
 - (b) if the equipment is fitted to a trailer that is being towed by an eligible towing vehicle and the equipment must be connected to the eligible towing vehicle to perform its intended function — connected to the eligible towing vehicle.

[r 20]

(2) In this rule:

eligible towing vehicle, for a trailer, means a towing vehicle that has equipment that is capable of being connected to the equipment fitted to the trailer.

Part 3 Australian Design Rules

Note This Part applies the second and third edition ADRs to various vehicles.

Under this Part, a vehicle that is subject to ADRs when it is built generally remains subject to the ADRs throughout its life. However, a vehicle need not comply with a standard if the standard is replaced by, or inconsistent with, a later standard and the vehicle complies with the later standard. As a result, older vehicles may be fitted with any equipment allowed on newer vehicles.

Vehicles that are modified must continue to comply with the Light Vehicle Standards. For guidance on vehicle modifications see *Vehicle Standards Bulletin No. 14 - Light Vehicle Modifications*.

(See <http://www.dotars.gov.au/transreg/vsb/index.aspx>)

Rule 33 (7) (Horns, alarms etc.) of the Light Vehicle Standards modifies the effect of the corresponding ADR requirement.

Rule 115 (Rear marking plates and conspicuity markings) of the Light Vehicle Standards extend the application of particular second or third edition ADRs to vehicles to which the ADRs are not expressed to apply.

The following provisions of the Light Vehicle Standards apply to a vehicle instead of the corresponding ADR requirement:

- rule 44 (6) to (7) (Window tinting)
- rule 50 (Tyres – manufacturer’s rating)
- rule 111 (Fitting of warning lights and signs)
- rule 114 (5) (Other lights and reflectors).

Division 1 Compliance with ADRs

21 Second edition ADRs

- (1) If a second edition ADR recommends that the ADR should apply to the design and construction of a vehicle, the vehicle must comply with the ADR.
- (2) If a second edition ADR contains a requirement for a type of equipment fitted to a vehicle built on or after a stated time, any equipment of the same type fitted to the vehicle after it is built must comply with:
 - (a) the requirement as in force when the vehicle was built; or
 - (b) if the requirement is amended after the vehicle is built and before the equipment is fitted — the requirement as in force:
 - (i) when the vehicle was built; or
 - (ii) when the equipment was fitted; or
 - (iii) at any time between when the vehicle was built and the equipment was fitted.
- (3) However, a vehicle, or equipment fitted to a vehicle, need not comply with a recommendation or requirement of a second edition ADR if:
 - (a) the recommendation or requirement is replaced by, or is inconsistent with, a requirement of either of the following (each a **newer ADR**):
 - (i) a later version of the second edition ADR applying to the vehicle or equipment;
 - (ii) a third edition ADR applying to the vehicle or equipment;and
 - (b) the vehicle or equipment complies with the requirement of the newer ADR.
- (4) If a second edition ADR allows a vehicle built on or after a stated time to be fitted with equipment, a vehicle built before the time may also be fitted with the equipment.

22 Third edition ADRs

- (1) If a third edition ADR applies to the design and construction of a vehicle, the vehicle must comply with the ADR.
- (2) If a third edition ADR contains a requirement for a type of equipment fitted to a vehicle built on or after a stated time, any equipment of the same type fitted to the vehicle after it is built must comply with:
 - (a) the requirement as in force when the vehicle was built; or

[r 22]

- (b) if the requirement is amended after the vehicle is built and before the equipment is fitted — the requirement as in force:
 - (i) when the vehicle was built; or
 - (ii) when the equipment was fitted; or
 - (iii) at any time between when the vehicle was built and the equipment was fitted.
- (3) However, a vehicle, or equipment fitted to a vehicle, need not comply with a requirement of a third edition ADR if:
 - (a) the requirement is replaced by, or is inconsistent with, a requirement of a later version of the ADR applying to the vehicle or equipment; and
 - (b) the vehicle or equipment complies with the requirement of the later version.
- (4) If a third edition ADR allows a vehicle built on or after a stated time to be fitted with equipment, a vehicle built before the time may also be fitted with the equipment.

Note The following table contains a list of some terms used in the third edition ADRs and the corresponding term used in the Light Vehicle Standards.

Third edition ADRs	Light Vehicle Standards
dipped-beam headlamp	low-beam (for a headlight)
front fog lamp	front fog light
rear fog lamp	rear fog light
wheelguard	mudguard
main-beam headlamp	high-beam (for a headlight)
reversing lamp	reversing light
direction indicator lamp	direction indicator light
stop lamp	brake light
rear registration plate lamp	number plate light
front position (side) lamp	parking light
rear position (side) lamp	tail light
end-outline marker lamp	front or rear clearance light
external cabin lamp	external cabin light
internal lamp	interior light
side marker lamp	side marker light
daytime running lamp	daytime running light
rear reflex reflector, non-triangular	rear reflector

[r 22]

Third edition ADRs	Light Vehicle Standards
front reflex reflector, non-triangular	front reflector
side reflex reflector, non-triangular	side reflector

Division 2 Exemptions from compliance with ADRs

23 Vehicles that are not road vehicles

A vehicle need not comply with an ADR applied by rule 21 (1) or 22 (1) if:

- (a) before the repeal of the Motor Vehicle Standards Act, a determination or declaration under section 5B of that Act provided that the vehicle is not a road vehicle for the purposes of that Act; or
- (b) a determination under section 6 (5) (b) or (6) (b) of the Road Vehicle Standards Act provides that the vehicle is not a road vehicle for the purposes of that Act.

24 Vehicles subject to particular approvals

- (1) A vehicle need not comply with an ADR applied by rule 21 (1) or 22 (1) if:
 - (a) despite non-compliance with the ADR:
 - (i) before the repeal of the Motor Vehicle Standards Act an approval was given under section 10A (2) or (3) to place an identification plate on the vehicle; or
 - (ii) an approval is given under item 4 (2) or 6 (2) of Schedule 3 to the *Road Vehicle Standards (Consequential and Transitional Provisions) Act 2018* (Cwlth); and
 - (b) the vehicle complies with the approval conditions, if any.
- (2) A vehicle need not comply with an ADR applied by rule 21 (1) or 22 (1) if:
 - (a) either:
 - (i) before the repeal of the Motor Vehicle Standards Act the vehicle was permitted to be supplied to the market under section 14A (1) of that Act; or
 - (ii) an approval is given under item 11 (2) of Schedule 3 to the *Road Vehicle Standards (Consequential and Transitional Provisions) Act 2018* (Cwlth); and
 - (b) the vehicle complies with the approval conditions, if any.
- (3) A vehicle need not comply with an ADR applied by rule 21 (1) or 22 (1) if:
 - (a) before the repeal of the Motor Vehicle Standards Act the vehicle was permitted to be used in transport in Australia under section 15 (2) of that Act; and

[r 25]

- (b) the vehicle complies with the approval conditions, if any.

24A Vehicles subject to particular approvals etc under Road Vehicle Standards Act

A vehicle need not comply with an ADR applied by rule 21 (1) or 22 (1) if:

- (a) the vehicle satisfied an entry pathway under section 15 (2) of the Road Vehicle Standards Act; and
- (b) despite non-compliance with the ADR, the vehicle is entered on the RAV.

25 Partial exemption for personally imported vehicles

- (1) For this rule, *personally imported vehicle* means a vehicle built after 1968 imported into Australia by a person who:
 - (a) before the vehicle was imported into Australia, owned and used it for a continuous period of at least:
 - (i) for a vehicle owned by the person before 9 May 2000—3 months; or
 - (ii) in any other case—12 months; and
 - (b) has:
 - (i) if the vehicle was imported immediately before the repeal of the Motor Vehicle Standards Act—undertaken to comply with any requirements relating to road safety imposed for the vehicle under the *Motor Vehicle Standards Regulations 1989* (Cwlth); or
 - (ii) otherwise—complied with the rules made under the Road Vehicle Standards Act.
- (2) A personally imported vehicle must be fitted with:
 - (a) seat belts that are as effective as seat belts that meet an Australian Standard or British Standard for seat belts as in force when this rule commenced; and
 - (b) seat belt anchorages that meet the number and location requirements of second or third edition ADR 5; and
 - (c) child restraint anchorages that meet the number, location, accessibility, thread size and form requirements of second edition ADR 34 or third edition ADR 5 or 34; and
 - (d) head restraints that meet the number, location and size requirements of second or third edition ADR 22.
- (3) However, a personally imported vehicle need only meet the requirements of an ADR mentioned in subrule (2) if the ADR

[r 25]

recommends that it should apply, or applies, to a vehicle of the same type.

- (4) A personally imported vehicle need not otherwise comply with an ADR applied to its design and construction by rule 21 (1) or 22 (1).

Part 4 General safety requirements

Note For a vehicle to be operated safely, the vehicle needs to be properly designed to minimise the potential for accidents and harm to other road users.

This Part sets out various requirements covering the driver's view from a vehicle, the driver's control of a vehicle, protection of vehicle occupants and other road users, and other general safety features.

Division 1 All vehicles

26 Steering

- (1) A motor vehicle must have a right-hand drive if the vehicle:
 - (a) is less than 30 years old; and
 - (b) is required under a law of this jurisdiction to have a right-hand drive.
- (2) A motor vehicle has a right-hand drive if the centre of at least 1 steering control of the vehicle is to the right of, or in line with, the centre of the vehicle.
- (3) In relation to a motor vehicle built before 1 January 2005, a component of the steering system of the vehicle that is essential for effective steering of the vehicle must be built to transmit energy by mechanical means only.
- (4) Failure of a non-mechanical component of the steering system must not prevent effective steering of the vehicle.
- (5) This rule does not apply to a vehicle if the vehicle is built mainly for a purpose other than the transport of goods or people by road.

27 Turning ability

- (1) A motor vehicle must be able to turn in a circle not over 25 metres in diameter, measured by the outer edge of the tyre track at ground level.
- (2) The vehicle must be able to comply with subrule (1) whether it turns to the left or to the right.

28 Ability to travel backwards and forwards

A motor vehicle with an unloaded mass over 450 kilograms must be able to be driven both backwards and forwards when the driver is in the normal driving position.

29 Protrusions

- (1) An object fitted to a vehicle must be designed, built and fitted to the vehicle in a way that minimises the likelihood of injury to a person making contact with the vehicle.
- (2) However, subrule (1) does not apply to an object fitted to a vehicle if:
 - (a) the vehicle was designed before 1965 and the object was part of the design of the vehicle; or
 - (b) the object was fitted to the vehicle before 1965 in accordance with the law of the place where the object was fitted.

30 Driver's view and vehicle controls

A motor vehicle must be built:

- (a) to allow the driver a view of the road and of traffic to the front and sides of the vehicle so the driver can drive the vehicle safely; and
- (b) with its controls located so the driver can drive the vehicle safely.

31 Seating

A seat for a driver or passenger in a vehicle must be securely attached to the vehicle.

32 Mudguards

- (1) A vehicle must have a mudguard firmly fitted for each wheel or adjacent wheels.
- (2) However, subrule (1) does not apply to a vehicle if:
 - (a) the construction or use of the vehicle makes the fitting of mudguards unnecessary or impracticable; or
 - (b) the body or part of the body of the vehicle acts as a mudguard.

Examples of vehicles to which subrule (2) (a) applies:

1. Most road-making plant.
 2. Some agricultural equipment.
- (3) A mudguard may be up to:
 - (a) 230 millimetres above ground level; or
 - (b) on a vehicle built to be used off-road — 300 millimetres above ground level.

[r 33]

- (4) The outside of a rear mudguard, except a mudflap, of a vehicle that can be seen from the rear of the vehicle must be coloured white or silver if the vehicle:
 - (a) is at least 2.2 metres wide; and
 - (b) has a body the vertical measurement of which is under 300 millimetres at the rear, measured from the lowest point of the body above ground level to the highest point; and
 - (c) is not fitted with rear marking plates or conspicuity markings in accordance with rule 115.

33 Horns, alarms etc.

- (1) In this rule:

repeater horn means a device that makes a sound alternating between different tones or frequencies on a regular time cycle.
- (2) A motor vehicle must be fitted with at least 1 horn or other device that can give sufficient audible warning to other road users of the approach or position of the vehicle.
- (3) A motor vehicle must not be fitted with a device that can make a sound like the sound of a siren, exhaust whistle, compression whistle or repeater horn.
- (4) However, subrule (3) does not apply to:
 - (a) an exempt vehicle; or
 - (aa) a vehicle at least 25 years old and fitted as an emergency vehicle or police vehicle if the vehicle:
 - (i) is used only for exhibition purposes; or
 - (ii) is part of a collection of former emergency vehicles or police vehicles; or
 - (b) an anti-theft alarm if the alarm cannot be operated while the vehicle's ignition is on.
- (5) Also, a motor vehicle may be fitted with a device that emits a regular, intermittent sound while the vehicle is reversing or in reverse gear.
- (6) The device must not be louder than is necessary so the driver, and a person near the vehicle, can hear the device when it is operating.
- (7) The provision of the relevant ADR that corresponds to subrule (3) applies to a vehicle as if that provision did not contain a reference to a bell.

34 Rear vision mirrors

- (1) At least 1 rear vision mirror must be fitted to:
 - (a) a car; and

[r 35]

- (b) a motor trike with 2 front wheels; and
 - (c) a motor bike, or motor trike with 1 front wheel, built before July 1975.
- (2) At least 1 rear vision mirror must be fitted to each side of:
 - (a) a motor vehicle with a GVM over 3.5 tonnes; and
 - (b) a motor bike, or motor trike with 1 front wheel, built after June 1975.
- (3) A motor vehicle with a GVM not over 3.5 tonnes (except a motor vehicle mentioned in subrule (1) or (2)) must be fitted with:
 - (a) at least 1 rear vision mirror on the right side of the vehicle; and
 - (b) at least 1 rear vision mirror on the left side of the vehicle or inside the vehicle.
- (4) A rear vision mirror fitted to a motor vehicle as required by this rule must be fitted so that the vehicle's driver in a normal driving position can clearly see by reflection the road behind the vehicle and any following or overtaking vehicle.
- (5) A rear vision mirror fitted to a motor vehicle with a GVM over 3.5 tonnes must not project over 150 millimetres beyond the overall width of the vehicle, measured in accordance with the prescribed dimension requirements applying to the vehicle.
- (6) However, the rear vision mirror may project not over 230 millimetres beyond the widest part of the vehicle or combination if it can fold to project not over 150 millimetres beyond the overall width of the vehicle, measured in accordance with the prescribed dimension requirements applying to the vehicle.

35 Rear vision mirrors — surfaces

- (1) A rear vision mirror required to be fitted to the side of a motor vehicle with a GVM over 3.5 tonnes must have a reflecting surface of at least 150 square centimetres.
- (2) The reflecting surface of the rear vision mirrors that are required to be fitted to a motor bike or moped must:
 - (a) each be of the same curvature; and
 - (b) if convex, be part of a notional sphere with a radius of at least 1.2 metres.

36 Additional rear vision mirrors and surfaces

A motor vehicle may be fitted with additional rear vision mirrors or mirror surfaces that are flat or convex or a combination of flat and convex surfaces.

[r 37]

37 Automatic transmission

- (1) A motor vehicle fitted with an automatic transmission must have an engine starter mechanism that cannot operate when the transmission control is in a position to drive the vehicle.
- (2) A vehicle built after 1975 that is fitted with an automatic transmission must have an indicator in the driver's compartment showing the transmission control position.
- (3) Subrules (1) and (2) do not apply to a motor vehicle with less than 4 wheels.

38 Diesel engines

A motor vehicle propelled by a diesel engine must be fitted with a device preventing the engine from being started accidentally or inadvertently.

39 Bonnet securing devices

- (1) A motor vehicle with a moveable body panel forward of the windscreen that covers an engine or luggage storage or battery compartment, must have a device to secure the panel.
- (2) However, if the panel opens from the front in a way that partly or completely obstructs the driver's forward view through the windscreen, the panel must have primary and secondary devices to secure the panel.

40 Electrical wiring, components, connections and installations

- (1) The wiring of electrical equipment of a vehicle, except the high tension ignition wiring, must:
 - (a) be supported at intervals of not over 600 millimetres, unless the vehicle is a pole-type trailer with a pole with an adjustable length, or an extendible trailer; and
 - (b) be insulated at each of its joints; and
 - (c) be located where it cannot:
 - (i) become overheated; or
 - (ii) contact moving parts; or
 - (iii) come near enough to the fuel system to be a fire hazard; and
 - (d) be protected from chafing.
- (2) The electrical components of a vehicle must be securely mounted.
- (3) The electrical connectors between motor vehicles and trailers, for operation of the vehicle lights required by the Light Vehicle Standards, must comply with at least one of the following standards:

[r 41]

- Australian Standard AS 2513-1982 *Electrical Connections for Trailer Vehicles*
 - International Standards Organisation ISO 1185-1997
 - Society of Automotive Engineers SAE J 560 – 1998.
- (4) A trailer must be equipped with an electrical conductor, independent of the trailer coupling, that provides a return path between the electrical circuits of the trailer and towing vehicle.

41 Television receivers and visual display units

- (1) A television receiver or visual display unit must not be installed in a vehicle so any part of the image on the screen is visible to the driver from the normal driving position.
- (2) However, subrule (1) does not apply to:
- (a) a television receiver or visual display unit that cannot be operated when the vehicle is moving; or
 - (b) a driver's aid in any vehicle or a destination sign in a bus.

Examples of driver's aids:

1. Closed-circuit television security cameras.
 2. Dispatch systems.
 3. Navigational or intelligent highway and vehicle system equipment.
 4. Rearview screens.
 5. Ticket-issuing machines.
 6. Vehicle monitoring devices.
- (3) A television receiver, or visual display unit, and its associated equipment in a vehicle must be securely mounted in a position that:
- (a) does not obscure the driver's view of the road; and
 - (b) does not impede the movement of a person in the vehicle.

42 Requirement for windscreen to be fitted

A motor vehicle (but not including a motor bike, a motor trike or a moped) must be fitted with a windscreen if it is manufactured or designed to have a windscreen.

43 Windscreens and windows

- (1) In this rule:
- approved material* means material with the same characteristics as material mentioned in any of the following standards:

[r 41]

- Australian Standard AS R1-1965 *Safety Glass for Land Transport*
- Australian Standard AS R1-1968 *Safety Glass for Land Transport*
- Australian Standard AS 2080-1977 *Safety Glass for Vehicles*
- British Standard BS 857:1967 *Specification for Safety Glass for Land Transport*
- British Standard BS 5282:1975 *Specification for Road Vehicle Safety Glass*
- British Standard BS AU178:1980 *Specification for Road Vehicle Safety Glass*
- Japanese Industrial Standard JIS R 3211-1979 *Safety Glasses for Road Vehicles*
- American Standard ANSI Z26.1-1980 *Safety Code for Safety Glazing Materials for Glazing Motor Vehicles Operating on Land Highway.*

transparent material does not include any coating added to the windscreen, window or partition after its manufacture.

- (2) Transparent material used in a windscreen, window, or an interior partition, of a motor vehicle must be of approved material if:
 - (a) the vehicle was built after June 1953; or
 - (b) the material was first fitted to the vehicle after June 1953.

44 Window tinting

- (1) In this rule:

glazing:

- (a) means material that may be used in a windscreen, window or interior partition of a motor vehicle, through which the vehicle's driver can see the road; but
- (b) does not include a coating added after manufacture of the material.

luminous transmittance, for glazing or a coating on glazing, means the amount of light that can pass through the glazing as a percentage of the amount of light that would be transmitted if the glazing or coating were absent.

rear glazing, for a motor vehicle, means glazing used in a window or interior partition of the motor vehicle located behind the driver in the normal driving position.

- (2) Glazing used in a windscreen of a motor vehicle must have a luminous transmittance of at least 70%.

[r 45]

- (3) Glazing used in a windscreen of a motor vehicle must not be coated in a way that reduces its luminous transmittance.
- (4) However, subrules (2) and (3) do not apply to the greater of the following areas of a windscreen:
 - (a) the area above the highest point of the windscreen that is swept by a windscreen wiper;
 - (b) the upper 10% of the windscreen.
- (5) Glazing used in a window or interior partition of a motor vehicle must have a luminous transmittance of at least 70%.
- (6) Glazing used in a window or interior partition of a motor vehicle, other than rear glazing, may be coated to achieve a luminous transmittance of not less than 35%.
- (6A) If a motor vehicle is fitted with at least 1 rear vision mirror to each side of the vehicle, the motor vehicle's rear glazing may be coated to achieve a luminous transmittance of at least 20%.
- (6B) If all of the following apply to a motor vehicle, the motor vehicle's rear glazing may be coated to achieve a luminous transmittance of 0% or more:
 - (a) the vehicle is fitted with at least 1 rear vision mirror to each side of the vehicle;
 - (b) the vehicle is designed primarily for the carriage of goods;
 - (c) the vehicle has:
 - (i) at least 4 wheels; or
 - (ii) at least 3 wheels and a GVM of more than 1 tonne.

Note ADR (Definitions and Vehicle Categories) provides for the vehicle category of goods vehicles.

- (7) The requirements about luminous transmittance applying to glazing used in a window of a motor vehicle stated in a second edition ADR or third edition ADR do not apply to a window that has been coated as provided in subrules (6), (6A) or (6B).
- (8) Glazing used in a windscreen, window or interior partition of a motor vehicle that has been coated to reduce its luminous transmittance must not have a reflectance of more than 10%.

45 Windscreen wipers and washers

- (1) A motor vehicle with 3 or more wheels that is fitted with a windscreen must be fitted with at least 1 windscreen wiper unless a driver in a normal driving position can obtain an adequate view of the road ahead of the motor vehicle without looking through the windscreen.
- (2) At least 1 windscreen wiper fitted to the motor vehicle must:

[r 46]

- (a) be able to remove moisture from the part of the windscreen in front of the driver to allow the driver an adequate view of the road ahead of the motor vehicle when the windscreen is wet; and
 - (b) be able to be operated from a normal driving position; and
 - (c) for a motor vehicle built after 1934 — continue to operate until the wiper is switched off; and
 - (d) for a motor vehicle built after 1959 the driving position of which is nearer one side of the vehicle than the other:
 - (i) be able to remove moisture from the part of the windscreen in front of the driver, and a corresponding part of the windscreen on the other side of the centre of the motor vehicle, to allow the driver an adequate view of the road ahead of the motor vehicle when the windscreen is wet; and
 - (ii) if the windscreen wipers are operated by engine manifold vacuum — be provided with a vacuum reservoir or pump to maintain the efficient operation of the wiper or wipers while the vehicle is in motion.
- (3) The windscreen washer must be able to be operated from a normal driving position.

46 Wheels and tyres — size and capacity

- (1) In this rule:
radial ply tyre means a radial ply tyre within the meaning of ADR (Definitions and Vehicle Categories).
- (2) The wheels and tyres fitted to an axle of a vehicle must be of sufficient size and capacity to carry the part of the vehicle's gross mass transmitted to the ground through the axle.
- (3) For the purposes of subrule (1), the size and capacity of a pneumatic tyre to be fitted to a vehicle must be decided using a cold inflation pressure that is not more than the lesser of:
- (a) the pressure recommended by the tyre manufacturer; and
 - (b) a pressure of:
 - (i) for a radial ply tyre — 825 kilopascals; or
 - (ii) for another tyre — 700 kilopascals.

47 Pneumatic tyres for particular vehicles

A vehicle built after 1932 must be fitted with pneumatic tyres.

[r 48]

48 Pneumatic tyres — carcass construction

- (1) A vehicle must not have pneumatic tyres of different carcass construction fitted to the same axle, but the tyres may have different cord materials and a different number of plies.
- (2) However, subrule (1) does not apply to a tyre being used in an emergency as a temporary replacement for a tyre complying with the subrule.

49 Tyres — defects

A tyre fitted to a vehicle must be free of any apparent defect that could make the vehicle unsafe.

50 Tyres — manufacturer's rating

- (1) This rule applies to a motor vehicle if the vehicle:
 - (a) has 4 or more wheels; and
 - (b) was built after 1972.
- (2) However, this rule does not apply to a tyre if the tyre:
 - (a) is recommended by the vehicle builder as suitable for limited use on the vehicle in special circumstances at a speed less than the speed applying to the vehicle under subrule (3); or
 - (b) is being used in an emergency as a temporary replacement for a tyre complying with this rule.
- (3) A tyre fitted to a motor vehicle must, when first manufactured, have been rated by the tyre manufacturer as suitable for road use at the lesser of:
 - (a) a speed of at least:
 - (i) for a car with special features for off-road use — 140 kilometres an hour; or
Example for paragraph (a) (i) A four-wheel drive vehicle.
 - (ii) for another car — 180 kilometres an hour; or
 - (iii) for another motor vehicle — 120 kilometres an hour; and
 - (b) the vehicle's top speed.
- (4) This rule applies to a vehicle instead of the tyre speed category requirements in the relevant ADR.

51 Retreads

- (1) In this rule:
retread compliance date means the date nominated under a law of this jurisdiction for the purposes of this rule.
- (2) A tyre that is retreaded before the retread compliance date must not be used on a vehicle if:
 - (a) Australian Standard AS 1973-1976 *Retreaded Pneumatic Passenger Car and Light Truck Tyre* or Australian Standard AS 1973-1985 *Retreaded Pneumatic Passenger and Light Truck Tyre* applies to the tyre; and
 - (b) the tyre was retreaded after publication of the Australian Standard; and
 - (c) the tyre was not retreaded in accordance with Australian Standard AS 1973-1976 *Retreaded Pneumatic Passenger Car and Light Truck Tyre*, Australian Standard AS 1973-1985 *Retreaded Pneumatic Passenger and Light Truck Tyre* or Australian Standard AS 1973-1993 *Pneumatic Tyres — Passenger Car, Light Truck and Truck/Bus — Retreading and Repair Processes*.
- (3) A tyre that is retreaded after the retread compliance date must not be used on a vehicle if:
 - (a) Australian Standard AS 1973-1993 *Pneumatic Tyres — Passenger Car, Light Truck and Truck/Bus — Retreading and Repair Processes* applies to the tyre; and
 - (b) the tyre was not retreaded in accordance with that Australian Standard.

Note The Australian Standards mentioned in this rule require various markings on retreaded tyres. These may include a speed rating less than the rating originally marked on the tyre.

52 Tyre tread

- (1) A tyre on a motor vehicle must not have cleats or other gripping devices that could damage road surfaces.
- (2) Except at tread wear indicators, a tyre fitted to the vehicle must have a tread pattern at least 1.5 millimetres deep in all principal grooves on the tyre in a band that runs continuously:
 - (a) across the tyre width that normally comes into contact with the road; and
 - (b) around the whole circumference of the tyre.
- (3) A vehicle must not be fitted with a tyre that has been treated by recutting or regrooving the tread rubber, unless the tyre was:

- (a) constructed with an extra thickness of rubber designed for recutting or regrooving; and
- (b) labelled to indicate the construction.

(4) In this rule:

principal grooves, in relation to a tyre, means wide grooves, other than secondary grooves:

- (a) usually positioned in the central zone of the tyre tread but that may run across the tyre tread; and
- (b) in which tread wear indicators are usually located.

secondary grooves, in relation to a tyre, means shallow grooves in the tyre tread that may disappear during the life of the tyre through wear.

tread wear indicators, in relation to a tyre, means projections within a groove of the tyre that indicate the degree of wear on the tyre's tread.

Division 2 Additional requirements for motor bikes

53 Steering gear and handlebars

- (1) The handlebars on a motor bike, other than a motor bike in vehicle category LC or LD, must extend at least 250 millimetres, but not over 450 millimetres, on each side of the centre line of the vehicle.
- (1A) The handlebars on a motor bike in vehicle category LC or LD must extend at least 250 millimetres, but not over 550 millimetres, on each side of the centre line of the vehicle.

Note The LC and LD vehicle categories are defined in ADR (Definitions and Vehicle Categories).

- (2) In taking a measurement for subrule (1), mirrors and lights mounted on the handlebars of the motor bike are disregarded.
- (3) The lowest part of the hand grip on the handle bars must not be higher than 380 millimetres above the attachment point of the handlebars to the motor bike.
- (4) Hand grips on the handle bars must be fitted symmetrically.
- (5) If a motor bike has the head stem as the steering pivot point, the horizontal distance from the midpoint between the head stem bearings to the centre of the front wheel must not be over 550 millimetres.

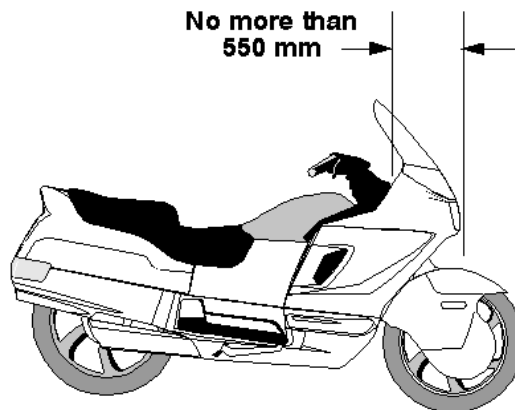

Maximum horizontal distance from midpoint between head stem bearings of motor bike to centre of front wheel

54 Foot rests

A motor bike must be fitted with foot rests for the driver, and for any passenger for whom a seating position is provided.

55 Chain guards

- (1) If the engine power of a motor bike is transmitted to the rear wheel by a chain, the driver and any passenger must be protected from the front sprocket and at least the upper part of the chain by:
 - (a) the frame or equipment of the motor bike; or
 - (b) a chain guard.
- (2) A chain guard must cover the chain to a point:
 - (a) at least 300 millimetres to the rear of the rearmost foot rest; or
 - (b) above the centre of the rear drive sprocket.

Part 5 Vehicle marking

Note This Part contains requirements for a vehicle that help to identify the vehicle and, if the vehicle is unusually long, to warn other motorists.

56 Engine and vehicle identification numbers

- (1) In this rule:
number includes letter.
- (2) A motor vehicle must have an individual engine identification number clearly stamped, embossed or otherwise permanently marked on it.
- (3) A motor vehicle built after 1930 must have the engine identification number on its engine block or the main component of its engine.
- (4) A vehicle must have an individual vehicle identification number clearly stamped, embossed or otherwise permanently marked on a substantial part of its frame or chassis.
- (5) An engine or vehicle identification number must be located where a person can read it easily without having to use tools to remove a part of the vehicle that would otherwise obstruct the person's view.

57 White or silver band on certain vehicles

- (1) This rule applies to a vehicle that:
 - (a) is at least 2.2 metres wide; and
 - (b) has a body with a vertical measurement under 300 millimetres at the rear, measured from the lowest point of the body above ground level to the highest point; and
 - (c) is not fitted with rear marking plates or conspicuity markings in accordance with rule 115.
- (2) The vehicle must have a white or silver band at least 75 millimetres high across the full width of the rearmost part of the body of the vehicle.

Part 6 Vehicle configuration and dimensions

Note This Part sets out various requirements covering the suspension on vehicles and size limits for single vehicles and combinations of vehicles, so that they can be operated safely with other traffic, without taking up too much road space or damaging the road and structures on the road.

Generally, the limits in this Part apply to a vehicle and any load it may be carrying.

Specific requirements for loaded vehicles are covered by other laws.

Division 1 Axles

58 Axle configuration

- (1) A motor vehicle must have only:
 - (a) 1 axle group, or single axle, towards the front of the vehicle; and
 - (b) 1 axle group, or single axle, towards the rear of the vehicle.
- (2) A trailer must have only:
 - (a) 1 axle group or single axle; or
 - (b) 2 axle groups, 2 single axles, or 1 axle group and single axle, in the following configuration:
 - (i) 1 axle group, or single axle, towards the front of the vehicle, with all the wheels on the axle group or single axle connected to the steering mechanism for that part of the trailer;
 - (ii) 1 axle group, or single axle, towards the rear of the vehicle.
- (3) A semi-trailer that is extendible, or is fitted with sliding axles, must:
 - (a) have a securing device that:
 - (i) can securely fix the extendible part or sliding axles to the rest of the vehicle in any position of adjustment provided; and
 - (ii) is located in a position that can prevent accidental or inadvertent release, if the device is mounted on the chassis of the vehicle; and
 - (iii) is fitted with a visible or audible warning system to indicate to a person standing beside the vehicle that the device is not engaged; and
 - (iv) is fitted with a way of preventing loss of air from the air brake supply, if the device uses air from the brake system and fails in a way allowing air to escape; and

[r 59]

- (v) is held in the applied position by direct mechanical action without the intervention of an electric, hydraulic or pneumatic device; and
- (b) be built so the adjustable parts of the vehicle remain connected if the securing device fails.

59 Retractable axles

- (1) In this rule:

retractable axle means an axle with a means of adjustment enabling the axle to be raised or lowered relative to the other axles in the axle group.

- (2) For the Light Vehicle Standards, a retractable axle is taken to be an axle only when the retractable axle is in the lowered position.

Division 2 Dimension requirements

60 Meaning of *rear overhang* and *rear overhang line*

- (1) The *rear overhang* of a vehicle is the distance between the rear of the vehicle and the rear overhang line of the vehicle.
- (2) For a vehicle with an axle group at the rear consisting of only 1 axle, the *rear overhang line* is a line running along the centre line of the axle.
- (3) For a vehicle with an axle group at the rear consisting of 2 axles, 1 of which is fitted with twice the number of tyres as the other, the *rear overhang line* is a line running parallel to the axles that is:
 - (a) closer to the axle carrying the greater number of tyres than the line is to the other axle; and
 - (b) located at one-third of the distance between the 2 axles.
- (4) For a vehicle with an axle group at the rear that is not an axle group mentioned in subrule (2) or (3), the *rear overhang line* is a line running parallel to the axles down the centre of the axle group.
- (5) For the purposes of applying subrule (2), (3) or (4) to a vehicle, if an axle group includes at least 1 steerable axle, that axle is to be disregarded unless:
 - (a) the group consists of only 1 axle and that axle is a steerable axle; or
 - (b) all the axles in the group are steerable axles.

Examples of rear overhang line:

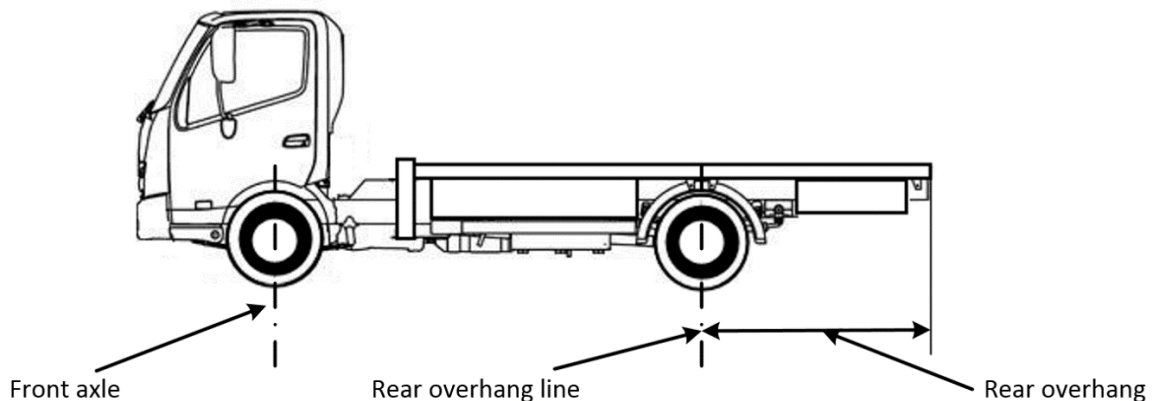

Rear overhang and rear overhang line — motor vehicle

[r 61]

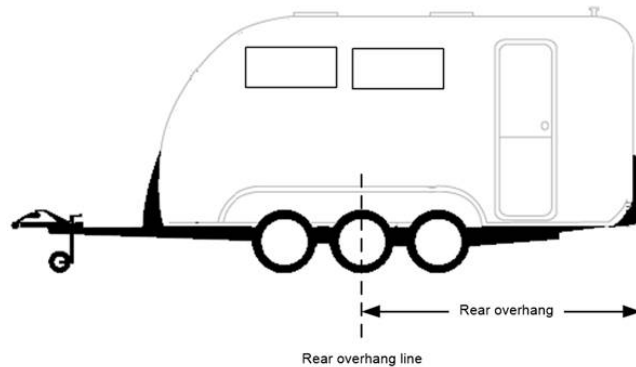

Rear overhang and rear overhang line — vehicle with tri-axle group at rear

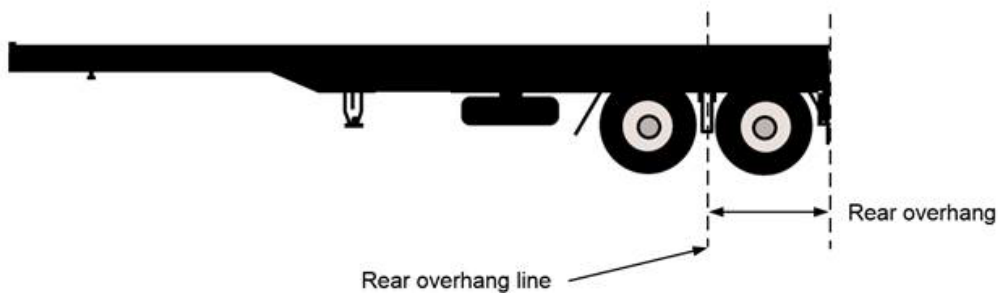

Rear overhang and rear overhang line — semi-trailer

61 Length of single motor vehicles

A motor vehicle must not be over 12.5 metres long.

62 Length of single trailers

- (1) On a semi-trailer or a dog trailer:
 - (a) the distance between the point of articulation at the front of the trailer and the rear overhang line must not be over 9.5 metres; and
 - (b) the distance between the point of articulation at the front of the trailer and the rear of the trailer must not be over 12.3 metres.
- (2) A projection forward of the point of articulation at the front of a semi-trailer must be contained within a radius of 1.9 metres from the point of articulation.

[r 63]

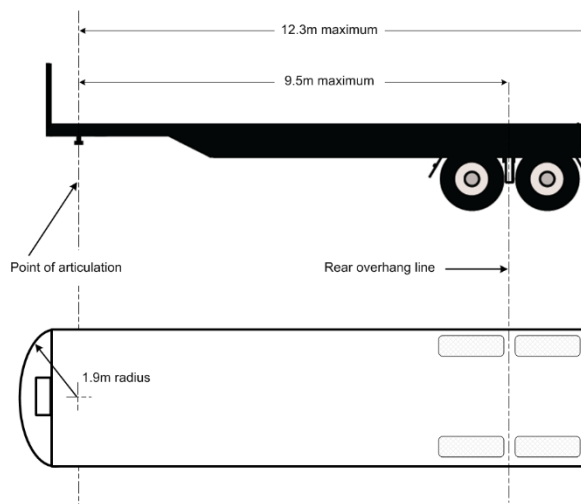

Maximum dimensions of a semi-trailer

63 Length of combinations

A combination must not be over 19 metres long.

64 Rear overhang

- (1) The rear overhang of a semi-trailer, or dog trailer consisting of a semi-trailer and converter dolly, must not exceed the lesser of:
 - (a) 60% of the distance between the point of articulation at the front and the rear overhang line; and
 - (b) 3.7 metres.
- (2) The rear overhang of a trailer with only 1 axle group or single axle (except a semi-trailer) must not exceed the lesser of:
 - (a) the length of the load-carrying area, or body, ahead of the rear overhang line; and
 - (b) 3.7 metres.
- (3) The rear overhang of a vehicle not mentioned in subrule (1) or (2) must not exceed the lesser of:
 - (a) 60% of the distance between the centre line of the front axle and the rear overhang line; and
 - (b) 3.7 metres.

65 Length — trailer drawbars

- (1) The distance between the coupling pivot point on the drawbar of a dog trailer, and the centre line of the front axle group or of the front single axle of the trailer, must not be over 5 metres.

[r 66]

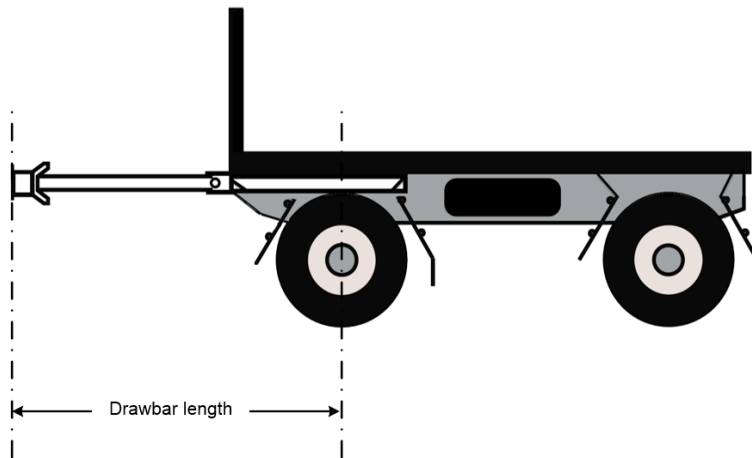

Length of a drawbar on a dog trailer

- (2) The distance between the coupling pivot point on a drawbar, and the centre line of the axle group or single axle on a trailer with only 1 axle group or single axle (except a semi-trailer) must not be over 8.5 metres.

66 Width

A vehicle must not be over 2.5 metres wide.

67 Height

A vehicle must not be over 4.3 metres high.

68 Ground clearance

- (1) In this rule:

ground clearance, of a vehicle, means the minimum distance to the ground from a point on the underside of the vehicle, except a point on a tyre, wheel, wheel hub, brake backing plate or flexible mudguard or mudflap of the vehicle.

- (2) A motor vehicle or combination must have a ground clearance of:
- (a) at least 100 millimetres at any point within 1 metre of an axle; and
 - (b) at the midpoint between adjacent axles — at least one-thirtieth of the distance between the centre lines of the axles; and
 - (c) at any other point — at least the distance that allows the vehicle or combination to pass over a peak in the road with a gradient on either side of 1:15, if the wheels of 1 axle of the vehicle or combination are on the slope on one side of the peak and the wheels of the next axle are on the slope on the other side.

[r 68]

- (3) However, subrule (2) does not apply to:
- (a) a motor vehicle with less than 4 wheels; or
 - (b) a combination that includes a motor vehicle with less than 4 wheels.

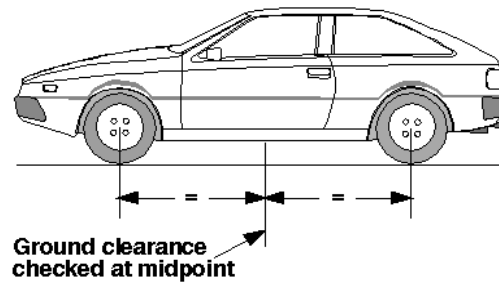

Ground clearance at the midpoint between 2 axles

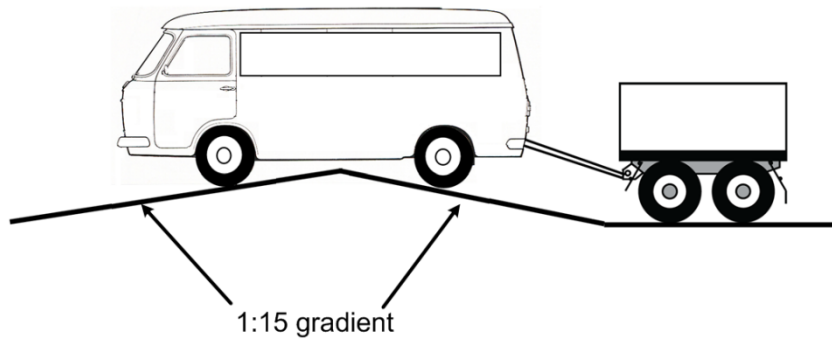

Ground clearance over a peak in the road

Part 7 Lights and reflectors

Note This Part deals with how the lights on a vehicle must be fitted and work so that the driver can see the road, pedestrians and other vehicles at night, and can signal to others.

Other laws provide for when certain lights must be switched on.

In this Part, the description ‘yellow’ is used as a more modern term, instead of the description ‘amber’ which is used in earlier legislation and some ADRs.

Division 1 Application of particular requirements

69 Part does not apply to particular vehicles

- (1) This Part does not apply to a vehicle built before 1931 that is used only in the daylight.
- (2) This Part does not apply to a vehicle built before 1946 that is used mainly for exhibition purposes.

70 Particular requirements apply only at night

The requirements of this Part for a light, except a brake or direction indicator light, to be visible over a stated distance apply only at night.

Division 2 General requirements for lights

71 Prevention of glare

A light, except a high-beam headlight, fitted to a vehicle must be built and adjusted to provide the necessary amount of light, without dazzling the driver of another vehicle approaching, or being approached by, the vehicle.

72 Pairs of lights

- (1) If lights are required under the Light Vehicle Standards to be fitted to a vehicle in pairs:
 - (a) a light must be fitted on each side of the longitudinal axis of the vehicle; and
 - (b) the centre of each light in a pair must be the same distance from the longitudinal axis of the vehicle; and
 - (c) the centre of each light in a pair must be at the same height above ground level; and
 - (d) each light in a pair must project approximately the same amount of light of the same colour.
- (2) Subrule (1) applies to a motor bike with an attached sidecar as if the sidecar were not attached.

Division 3 Headlights

73 Headlights to be fitted to vehicles

- (1) A motor vehicle must be fitted with:
 - (a) 1 low-beam headlight if it is a moped, motor bike, or motor trike with 1 front wheel; or
 - (b) a pair of low-beam headlights if it has 4 or more wheels or is a motor trike, except a moped, with 2 front wheels.
- (2) If a motor vehicle built after 1934 can travel at over 60 kilometres an hour:
 - (a) each low-beam headlight mentioned in subrule (1) must be able to work in the high-beam position; or
 - (b) the vehicle must be fitted with:
 - (i) 1 headlight that can work in the high-beam position if the vehicle is required to have 1 low-beam headlight; or
 - (ii) a pair of headlights that can work in the high-beam position.
- (3) A motor bike may be equipped with a headlight modulation system that:
 - (a) varies the brightness of its high-beam headlight or low-beam headlight, but not both, at a rate of at least 200 and at most 280 flashes a minute; and
 - (b) is designed to operate only in the daylight.
- (4) Up to 4 additional headlights may be fitted to a motor vehicle with 4 or more wheels, a motor bike or a motor trike.
- (5) An additional headlight fitted to a vehicle must be fitted so that it faces forward and is symmetrical in relation to the centre-line of the vehicle.

Example—

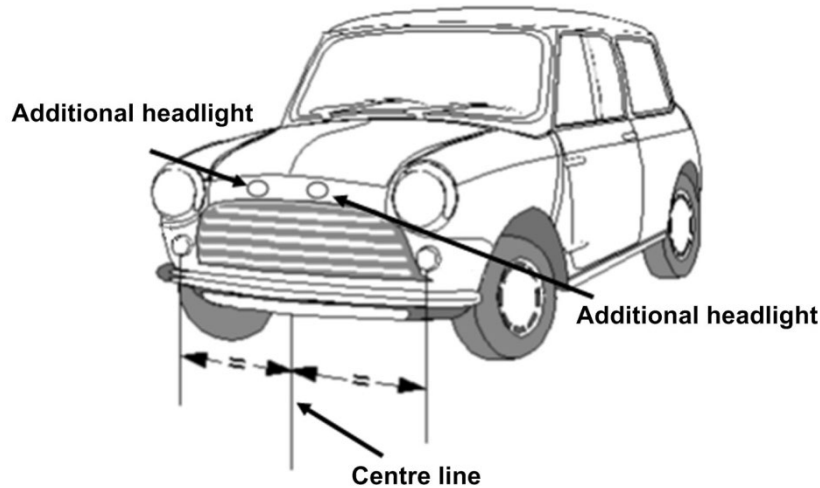

74 How headlights are to be fitted

- (1) The centres of low-beam headlights fitted as a pair on a motor vehicle with 4 or more wheels must be at least 600 millimetres apart.
- (2) However, subrule (1) does not apply to a motor vehicle built before 1970 if the centres of its low-beam headlights:
 - (a) were under 600 millimetres apart when the vehicle was built; and
 - (b) are not nearer than they were when the vehicle was built.
- (3) Each low-beam headlight of a pair on a motor trike (except a moped) with 2 front wheels must not be over 400 millimetres from the nearer side of the vehicle.
- (4) The centre of a low-beam headlight fitted to a motor vehicle built after June 1953 must be:
 - (a) at least 500 millimetres above ground level; and
 - (b) not over 1.4 metres above ground level.

75 How single headlights are to be fitted

- (1) A motor bike or motor trike with a single headlight fitted must have the light fitted in the centre.
- (2) Subrule (1) applies to a motor bike with an attached sidecar as if the sidecar were not attached.

[r 77]

77 Performance of headlights

- (1) When on, a headlight, or additional headlight, fitted to a vehicle must:
 - (a) show only white light; and
 - (b) project its main beam of light ahead of the vehicle.
- (2) Headlights must be fitted to a vehicle so their light does not reflect off the vehicle into the driver's eyes.

78 Effective range of headlights

- (1) This rule applies to a headlight that is on at night.
- (2) A low-beam headlight must illuminate the road ahead of the vehicle for at least 25 metres.
- (3) A high-beam headlight must illuminate the road ahead of the vehicle for at least 50 metres.
- (4) However, a low-beam headlight fitted to a motor vehicle built before 1931, or a moped, need only illuminate the road ahead of the vehicle for 12 metres.

79 Changing headlights from high-beam to low-beam position

- (1) A motor vehicle built after 1934 that can travel at over 60 kilometres an hour must be fitted with:
 - (a) a dipping device enabling the driver in the normal driving position:
 - (i) to change the headlights from the high-beam position to the low-beam position; or
 - (ii) simultaneously to switch off a high-beam headlight and switch on a low-beam headlight; and
 - (b) for a vehicle built after June 1953 — a device to indicate to the driver that the headlights are in the high-beam position.
- (2) A headlight fitted to a vehicle not fitted with a dipping device mentioned in subrule (1) (a) must operate in the low-beam position.
- (3) When a headlight fitted to a vehicle is switched to the low-beam position, any other headlight on the vehicle must operate only in the low-beam position or be off.

Division 4 Parking lights

80 Parking lights

- (1) A motor vehicle built after June 1953 must be fitted with:
 - (a) a pair of parking lights if it is a motor trike with 2 front wheels (except a moped) or a motor vehicle with 4 or more wheels; or
 - (b) at least 1 parking light if it is a motor bike with an attached sidecar, or a motor trike with 1 front wheel, (except a moped).
- (2) A pair of parking lights fitted to a motor vehicle with 4 or more wheels must be fitted with the centre of each light:
 - (a) at least 600 millimetres from the centre of the other light; and
 - (b) not over 510 millimetres from the nearer side of the vehicle.
- (3) However, a pair of parking lights fitted to a motor vehicle under 1300 millimetres wide may be fitted with the centre of each light not under 400 millimetres from the centre of the other light.
- (4) A parking light fitted to a motor trike with 2 front wheels must not be over 400 millimetres from the nearer side of the vehicle.
- (5) A parking light fitted to a motor bike with a sidecar must be fitted not over 150 millimetres from the side of the sidecar furthest from the motor bike.

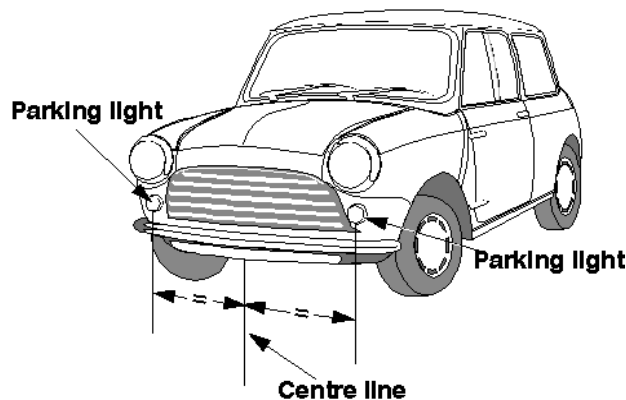

Location of parking lights on a vehicle

- (6) When on, a parking light must:
 - (a) show a white or yellow light visible 200 metres from the front of the vehicle; and
 - (b) not use over 7 watts of power.

[r 80]

- (7) A parking light fitted to a motor vehicle built after 1969 must be wired so the parking light is on when a headlight on the vehicle is on.
- (8) A parking light fitted to a sidecar attached to a motor bike must be wired to operate when a headlight, tail light or parking light on the motor bike is on.

Division 5 Daytime running lights

81 Daytime running lights

- (1) A pair of daytime running lights may be fitted to a motor vehicle.
- (2) A pair of daytime running lights fitted to a vehicle with 4 or more wheels must be fitted with the centre of each light:
 - (a) at least 600 millimetres from the centre of the other light; and
 - (b) not over 510 millimetres from the nearer side of the vehicle.
- (3) However, a pair of daytime running lights fitted to a motor vehicle under 1300 millimetres wide may be fitted with the centre of each light not under 400 millimetres from the centre of the other light.

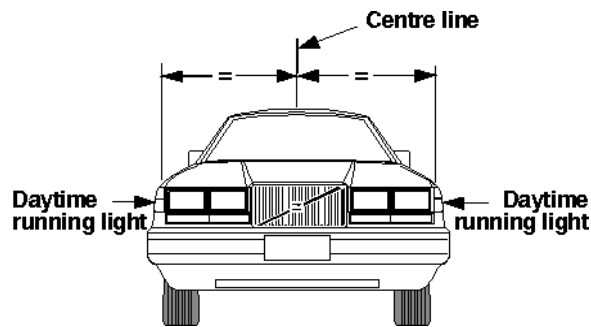

Location of daytime running lights on a vehicle

- (4) When on, a daytime running light must:
 - (a) show a white or yellow light visible from the front of the vehicle; and
 - (b) not use over 25 watts of power.

Note The third edition ADRs only allow white daytime running lights.
- (5) Daytime running lights must be wired so they are off when a headlight, except a headlight being used as a flashing signal, is on.

Division 6 Tail lights

82 Tail lights generally

- (1) A vehicle must have at least 1 tail light fitted on or towards the rear of the vehicle.
- (2) A motor trike with 2 rear wheels, or a motor vehicle with 4 or more wheels, built after 1959 must have at least 1 tail light fitted on or towards each side of the rear of the vehicle.
- (3) A trailer built after June 1973 must have at least 1 tail light fitted on or towards each side of the rear of the vehicle.
- (4) The centre of a tail light mentioned in subrule (1), (2) or (3) must not be over:
 - (a) 1.5 metres above ground level; or
 - (b) if it is not practicable to fit the light lower — 2.1 metres above ground level.
- (5) A vehicle may have 1 or more additional tail lights at any height above ground level.

83 Pattern of fitting tail lights

- (1) If only 1 tail light is fitted to a vehicle, it must be fitted in the centre or to the right of the centre of the vehicle's rear.
- (2) Subrule (1) applies to a motor bike with an attached sidecar as if the sidecar were not attached.
- (3) If 2 or more tail lights are fitted to a vehicle, at least 2 tail lights must be fitted as a pair.

[r 84]

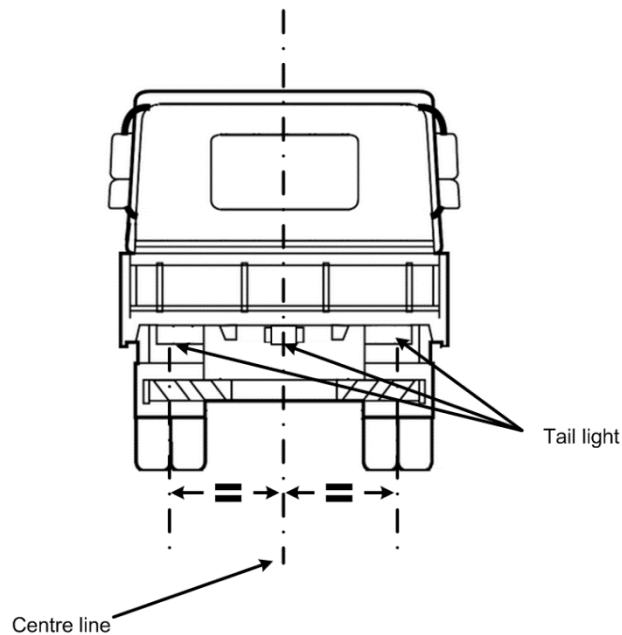

Location of tail lights on a vehicle

- (4) Tail lights fitted in accordance with this Division may also serve as rear clearance lights if they are fitted to a vehicle in accordance with rule 89 (3).

84 Performance of tail lights

- (1) When on, a tail light of a vehicle must:
- (a) show a red light visible 200 metres from the rear of the vehicle; and
 - (b) not use over 7 watts of power.
- (2) A tail light fitted to a street rod vehicle may incorporate a blue lens not over 20 millimetres in diameter.

85 Wiring of tail lights

A tail light of a motor vehicle must be wired to come on, and stay on, when a parking light or headlight on the vehicle is on, unless an external switch is fitted to operate the tail light.

Division 7 Number plate lights

86 Number plate lights

- (1) At least 1 number plate light must be fitted to the rear of a vehicle.
- (2) When on, the number plate light or lights must illuminate a number plate on the rear of the vehicle with white light, so the characters on the number plate can be read at night 20 metres from the rear of the vehicle.
- (3) A number plate light:
 - (a) may be combined with another light; and
 - (b) must not project white light to the rear of the vehicle except by reflection; and
 - (c) must not obscure the characters on the number plate; and
 - (d) must be wired to come on, and stay on, when a parking light, headlight or tail light on the vehicle is on.

Division 8 Clearance lights

87 Front clearance lights

- (1) Front clearance lights may only be fitted to a vehicle that is at least 1.8 metres wide.
- (2) A pair of front clearance lights must be fitted to a motor vehicle that is at least 2.2 metres wide, or a prime mover.
- (3) The centre of a front clearance light must be:
 - (a) not over 400 millimetres from the nearer side of the vehicle; and
 - (b) if the vehicle was built after June 1953:
 - (i) at least 750 millimetres higher than the centre of any low-beam headlight fitted to the vehicle; or
 - (ii) not lower than the top of the windscreen.
- (4) However, a front clearance light may be mounted on an external rear vision mirror or a mirror support if, when the mirror is correctly adjusted, no part of the lens of the clearance light is visible to a person in the normal driving position.
- (5) When on, a front clearance light must:
 - (a) show a yellow or white light visible 200 metres from the front of the vehicle; and
 - (b) not use over 7 watts of power.

88 External cabin lights

- (1) A motor vehicle fitted with front clearance lights may also have additional forward-facing lights on or above the roof of its cabin.
- (2) The additional forward-facing lights must be spaced evenly between the front clearance lights, with their centres at least 120 millimetres apart.
- (3) When on, an additional forward-facing light must:
 - (a) show a yellow or white light; and
 - (b) not use over 7 watts of power.

89 Rear clearance lights

- (1) Rear clearance lights may only be fitted to a vehicle that is at least 1.8 metres wide.
- (2) A pair of rear clearance lights must be fitted to the rear of a vehicle that is at least 2.2 metres wide.

[r 89]

- (3) The centre of a rear clearance light must be:
 - (a) not over 400 millimetres from the nearer side of the vehicle; and
 - (b) if practicable, at least 600 millimetres above ground level.
- (4) When on, a rear clearance light must:
 - (a) show a red light visible 200 metres from the rear of the vehicle;
and
 - (b) not use over 7 watts of power.

Division 9 Side marker lights

90 Vehicles needing side marker lights

- (1) A pair of side marker lights must be fitted towards the rear of the sides of a motor vehicle that is over 7.5 metres long and at least 2.2 metres wide.
- (2) A pole-type trailer, and a motor vehicle built to tow a pole-type trailer, with at least 1 cross-bar or bolster must have a side marker light fitted to each side of the back or only cross-bar or bolster.
- (3) A pole-type trailer with 2 or more cross-bars or bolsters may also have a side marker light fitted to each side of the front cross-bar or bolster.
- (4) At least 2 side marker lights must be fitted to each side of:
 - (a) a trailer, except a pole-type trailer, that is at least 2.2 metres wide and not over 7.5 metres long; or
 - (b) a semi-trailer that is not over 7.5 metres long.
- (5) At least 3 side marker lights must be fitted to each side of:
 - (a) a trailer, except a pole-type trailer, that is at least 2.2 metres wide and over 7.5 metres long; or
 - (b) a semi-trailer that is over 7.5 metres long.

91 Location of side marker lights

- (1) The centre of a side marker light must not be over 150 millimetres from the nearer side of the vehicle.
- (2) A front side marker light fitted to a motor vehicle must be towards the front of the side of the vehicle with no part of the lens visible to the driver.
- (3) The centre of a front side marker light fitted to a trailer must be:
 - (a) within 300 millimetres of the front of the side of the trailer; or
 - (b) if the construction of the trailer makes it impracticable to comply with paragraph (a) — as near as practicable to the front of the trailer.
- (4) The centre of a rear side marker light fitted to a vehicle must be:
 - (a) within 300 millimetres of the rear of the side of the vehicle; or
 - (b) if the construction of the vehicle makes it impracticable to comply with paragraph (a) — as near as practicable to the rear of the vehicle.
- (5) Side marker lights fitted to a vehicle must, as far as practicable, be evenly spaced along the side of the vehicle.

[r 92]

- (6) Subrules (2) to (5) do not apply to side marker lights fitted to a cross-bar or bolster of a pole-type trailer.
- (7) Only the side marker lights nearest to the rear need be fitted if complying with subrules (3) and (4) would result in the front and rear side marker lights being under 2.5 metres apart.
- (8) A side marker light fitted to a vehicle must be fitted so:
 - (a) its centre is not over:
 - (i) 1.5 metres above ground level; or
 - (ii) if it is not practicable to fit it lower — 2.1 metres above ground level; and
 - (b) its centre is at least 600 millimetres above ground level; and
 - (c) it is, as far as practicable, in a row of side marker lights along the side of the vehicle.
- (9) Subrule (8) (a) does not apply to a side marker light that is not required to be fitted to the vehicle by rule 90.

92 Performance of side marker lights

- (1) When on, a side marker light fitted to a vehicle must:
 - (a) show a light visible 200 metres from the vehicle; and
 - (b) not use over 7 watts of power.
- (2) When on, a side marker light fitted to a vehicle must show:
 - (a) to the front of the vehicle — a yellow light; and
 - (b) to the rear of the vehicle:
 - (i) if the light also operates as a rear light or reflector — a red light; and
 - (ii) in any other case — a red or yellow light.
- (3) However, if a pole-type trailer with 2 or more cross-bars or bolsters has the side marker lights permitted by rule 90 (3):
 - (a) the side marker lights fitted to the front cross-bar or bolster may comply with subrule (2) (a) only; and
 - (b) the side marker lights fitted to the back cross-bar or bolster may comply with subrule (2) (b) only.

93 Side marker lights and rear clearance lights

The side marker light nearest to the rear of a vehicle may also be a rear clearance light for rule 89.

Division 10 Brake lights

94 Fitting brake lights

- (1) A brake light must be fitted to the rear of a vehicle built after 1934.
- (2) A pair of brake lights must be fitted to the rear of:
 - (a) a motor vehicle built after 1959 that has 4 or more wheels; and
 - (b) a motor trike built after 1959 that has 2 rear wheels; and
 - (c) a trailer built after June 1973.
- (3) The centre of a brake light must be:
 - (a) at least 350 millimetres above ground level; and
 - (b) not over:
 - (i) 1.5 metres above ground level; or
 - (ii) if it is not practicable to fit the light lower — 2.1 metres above ground level.
- (4) A vehicle may be fitted with 1 or more additional brake lights.
- (5) The centre of an additional brake light must be at least 350 millimetres above ground level.
- (6) If only 1 brake light is fitted to a vehicle, it must be fitted in the centre or to the right of the centre of the vehicle's rear.
- (7) Subrule (6) applies to a motor bike with an attached sidecar as if the sidecar were not attached.
- (8) For the purposes of this rule, a light fitted to a vehicle that functions as a brake light and a direction indicator light is taken to be a brake light if the vehicle was built before 1 January 1973.

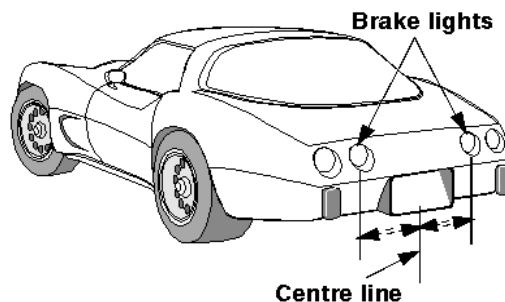

Location of brake lights on a vehicle

95 Performance and operation of brake lights

- (1) When on, a brake light must show a red light visible 30 metres from the rear of the vehicle.
- (2) A brake light fitted to a street rod vehicle may incorporate a blue lens not over 20 millimetres in diameter.
- (3) A brake light fitted to a motor vehicle must come on, if it is not already on, when:
 - (a) for a vehicle with 4 or more wheels or built after 1974 — a service brake is applied; or
 - (b) for another vehicle — the rear wheel brake is applied.
- (4) Subrule (3) does not apply if the controls in the vehicle that start the engine are in a position that makes it impossible for the engine to operate.
- (5) A brake light on a trailer must come on when:
 - (a) the brake light of the towing vehicle comes on; or
 - (b) a brake control on the towing vehicle, which independently activates the service brake on the trailer, is operated.
- (6) A brake light may be operated by an engine brake, retarder, or similar device if the device does not interfere with the proper operation of the brake light.

Division 11 Reversing lights

96 Reversing lights

- (1) One or more reversing lights may be fitted to the rear of a vehicle and on each side towards the rear of the vehicle.
- (2) A reversing light must have its centre not over 1.2 metres above ground level.
- (3) When on, a reversing light must show a white or yellow light to the rear or to the side and rear of the vehicle.

Note Third edition ADRs only allow white reversing lights.

- (4) A reversing light fitted to a motor vehicle must be wired so it operates only when the vehicle is reversing or in reverse gear.
- (5) A reversing light fitted to a trailer must be wired so it operates only when a motor vehicle towing the trailer is reversing or in reverse gear.
- (6) A yellow reversing light may also operate as a direction indicator light.

Division 12 Direction indicator lights

97 Direction indicator lights on motor vehicles

- (1) A motor vehicle with 4 or more wheels that was built after August 1966 must have:
 - (a) a pair of direction indicator lights fitted on, or towards, its front that face forwards; and
 - (b) a pair of direction indicator lights fitted on, or towards, its rear that face backwards.
- (2) A motor vehicle with less than 4 wheels that was built after June 1975 must have:
 - (a) a pair of direction indicator lights fitted on, or towards, its front that face forwards; and
 - (b) a pair of direction indicator lights fitted on, or towards, its rear that face backwards.
- (3) A motor vehicle that is not required to have direction indicator lights may have:
 - (a) 1 or more pairs of direction indicator lights that are visible from both the front and rear of the vehicle; or
 - (b) both:
 - (i) a pair of direction indicator lights fitted on, or towards, its front that face forwards; and
 - (ii) a pair of direction indicator lights fitted on, or towards, its rear that face backwards.

98 Direction indicator lights on trailers

- (1) A trailer built after June 1973 must have a pair of direction indicator lights fitted on, or towards, its rear that face backwards.
- (2) A trailer that is not required to have direction indicator lights may have 1 or more pairs of direction indicator lights fitted on, or towards, its rear that face backwards.

99 Location of direction indicator lights

- (1) A pair of direction indicator lights fitted to a vehicle must have the centre of each light at least:
 - (a) for a motor bike or the single wheel end of a motor trike — 300 millimetres from the centre of the other light; and

[r 100]

- (b) for lights fitted at the 2 wheel end of a motor trike — 600 millimetres from the centre of the other light, unless the centre of each direction indicator light is not over 400 millimetres from the nearer side of the vehicle; and
 - (c) for another vehicle with a width of not over 1300 millimetres — 400 millimetres from the centre of the other light; and
 - (d) for another vehicle with a width of over 1300 millimetres — 600 millimetres from the centre of the other light.
- (2) The centre of each direction indicator light must be at least 350 millimetres above ground level.
 - (3) The centre of each light in a pair of direction indicator lights required to be fitted to a vehicle must not be over:
 - (a) 1.5 metres above ground level; or
 - (b) if it is not practicable for the light to be fitted lower — 2.1 metres above ground level.

100 Operation and visibility of direction indicator lights

- (1) A direction indicator light fitted to a motor vehicle must:
 - (a) when operating, display regular flashes of light at a rate of not over 120 flashes a minute and:
 - (i) for a motor vehicle with 4 or more wheels — at least 60 flashes a minute; and
 - (ii) for another motor vehicle — at least 45 flashes a minute; and
 - (b) be able to be operated by a person in the normal driving position; and
 - (c) be wired to an audible or visible device in the vehicle that tells the driver that the direction indicator light is operating; and
 - (d) flash at the same time and rate as any other direction indicator lights fitted on the same side of the vehicle.
- (2) A direction indicator light fitted to a side of a trailer must, when operating, flash at the same time and rate as the direction indicator light or lights fitted to the same side of the motor vehicle towing the trailer.
- (3) The flashes of light displayed by a direction indicator light must be:
 - (a) if the light faces forwards — white or yellow; and
 - (b) if the light faces backwards:
 - (i) yellow; or
 - (ii) for a vehicle built before July 1973 — yellow or red; and
 - (c) if the light faces out from the side of the vehicle:

[r 100]

- (i) white or yellow towards the front and side; and
- (ii) for a vehicle built before July 1973 — yellow or red towards the rear and side; and
- (iii) for a vehicle built after June 1973 — yellow towards the rear and side.

Note The ADRs only allow yellow direction indicator lights.

- (4) If a motor vehicle's direction indicator lights display only yellow light, the vehicle may be equipped to allow the lights to operate simultaneously on both sides of the vehicle, if a visible or audible signal tells the driver when the lights are operating simultaneously.
- (5) When on, a direction indicator light must be visible 30 metres from:
 - (a) if the light faces forwards — the front of the vehicle; or
 - (b) if the light faces backwards — the rear of the vehicle; or
 - (c) if the light faces out from the side of the vehicle — that side of the vehicle.
- (6) When on, each direction indicator light in at least 1 pair of lights fitted on or towards the front of a prime mover, or a motor vehicle over 7.5 metres long, must be visible at a point:
 - (a) 1.5 metres at right angles from the side of the vehicle where the light is fitted; and
 - (b) in line with the rear of the vehicle.

Division 13 Fog lights

101 Front fog lights

- (1) A pair of front fog lights may be fitted to a motor vehicle with 4 or more wheels.
- (2) A pair of front fog lights, or a single front fog light, may be fitted to a motor bike or motor trike.
- (3) A pair of front fog lights fitted to a motor vehicle with 4 or more wheels must have the centre of each light not over 400 millimetres from the nearer side of the vehicle unless the centres of the lights are at least 600 millimetres apart.
- (4) If the top of the front fog light is higher than the top of any low-beam headlight on the vehicle, the centre of the fog light must not be higher than the centre of the low-beam headlight.
- (5) A front fog light must:
 - (a) when on:
 - (i) project white or yellow light in front of the vehicle; and
 - (ii) be a low-beam light; and
 - (b) be able to be operated independently of any headlight; and
 - (c) be fitted so the light from it does not reflect off the vehicle into the driver's eyes.

102 Rear fog lights

- (1) In this rule:

rear fog light means a light used on a vehicle to make the vehicle more easily visible, from the rear, in dense fog.
- (2) A vehicle may have fitted to its rear:
 - (a) a pair of rear fog lights; or
 - (b) 1 rear fog light fitted on, or to the right, of the centre of the vehicle.
- (3) Subrule (2) (b) applies to a motor bike with an attached sidecar as if the sidecar were not attached.
- (4) A rear fog light must:
 - (a) have its centre:
 - (i) not over 1.5 metres above ground level; and
 - (ii) at least 100 millimetres from the centre of a brake light; and
 - (b) when on, project red light behind the vehicle; and

[r 102]

- (c) not use over 27 watts of power; and
- (d) be wired to a visible device in the vehicle that tells the driver that the rear fog light is operating.

Division 14 Interior lights

103 Interior lights

A vehicle may be fitted with interior lights that illuminate any interior part of the vehicle.

Division 15 Reflectors generally

104 General requirements for reflectors

- (1) A reflector fitted to a vehicle must show a red, yellow or white reflection of light when light is projected directly onto the reflector at night by a low-beam headlight that:
 - (a) is 45 metres from the reflector; and
 - (b) complies with the Light Vehicle Standards.
- (2) The reflection must be clearly visible from the position of the headlight.

Division 16 Rear reflectors

105 Rear reflectors

- (1) A motor vehicle with 4 or more wheels, and a trailer, must have a rear-facing red reflector towards each side of its rear.
- (2) A motor bike, a sidecar attached to a motor bike, and a motor trike, must have a rear-facing red reflector.
- (3) The centre of each reflector must be:
 - (a) at the same height above ground level; and
 - (b) not over 1.5 metres above ground level.
- (4) However, subrule (3) does not apply to a reflector fitted to a sidecar attached to a motor bike.
- (5) A reflector fitted to a motor vehicle with 4 or more wheels, or a trailer, must not be over 400 millimetres from the nearer side of the vehicle.
- (6) A vehicle fitted with rear-facing red reflectors in accordance with subrule (1) or (2) may be fitted with additional red reflectors at any height above ground level or at any distance from the side of the vehicle.

Division 17 Side reflectors

106 Compulsory side reflectors on pole-type trailers

- (1) Yellow or red side-facing reflectors must be fitted to the pole of a pole-type trailer so:
 - (a) 1 reflector is fitted to the middle third of the left and right faces of the pole; and
 - (b) the front reflector is not over 3 metres from the front of the trailer; and
 - (c) the other reflectors are not over 3 metres apart.
- (2) Additional side-facing reflectors may be fitted to a pole-type trailer in accordance with rule 107.

107 Optional side reflectors

- (1) A vehicle may be fitted with side-facing reflectors.
- (2) A side-facing reflector:
 - (a) towards the front of the vehicle must be yellow or white; and
 - (b) towards the rear of the vehicle must be yellow or red; and
 - (c) on the central part of the vehicle must be yellow.

Division 18 Front reflectors

108 Compulsory front reflectors on particular trailers

- (1) A front-facing white or yellow reflector must be fitted towards each side of the front of:
 - (a) a semi-trailer, except a pole-type trailer; or
 - (b) the front cross-bar or bolster of a pole-type trailer; or
 - (c) a trailer that is at least 2.2 metres wide.
- (2) Each reflector must have its centre:
 - (a) at the same height above ground level; and
 - (b) not over 1.5 metres above ground level; and
 - (c) not over 400 millimetres from the nearer side of the vehicle.
- (3) Additional front-facing reflectors may be fitted to a trailer mentioned in subrule (1) in accordance with rule 109.

109 Optional front reflectors

- (1) A motor vehicle with 4 or more wheels, or a trailer, may have 1 or more front-facing white or yellow reflectors fitted towards each side of its front.
- (2) A motor vehicle with less than 4 wheels may have 1 or more front-facing white or yellow reflectors.
- (3) The centre of at least 1 reflector on each side of the front of the vehicle must be:
 - (a) at the same height above ground level as the centre of the other reflector; and
 - (b) the same distance from the longitudinal axis of the vehicle as the centre of the other reflector; and
 - (c) at least:
 - (i) for a vehicle with a width under 1300 millimetres — 400 millimetres from the centre of the other reflector; and
 - (ii) for another vehicle — 600 millimetres from the centre of the other reflector.

Division 19 Warning lights and signs on buses carrying children

110 Application of Division 19

This Division applies to a bus that is used mainly for carrying children if the bus is fitted with warning lights after June 1999.

Note For warning signs and lights fitted before July 1999, see rule 114.

111 Fitting of warning lights and signs

- (1) Two warning lights and a warning sign must be fitted to the front and rear of the bus.
- (2) The warning lights must be fitted:
 - (a) on each side of, and the same distance from, the centre of the warning sign; and
 - (b) with the edge of the warning sign not over 100 millimetres from the nearest point on the lens of the warning lights; and
 - (c) with the distance between the warning lights at least 300 millimetres at the nearest point; and
 - (d) so no part of the bus obstructs the light displayed:
 - (i) 30° to the left and right of the centre of each light; and
 - (ii) 10° above and below the centre of each light.
- (3) The warning lights may be on the warning sign if the words or image on the sign are not obscured.
- (4) The warning lights at the same end of the bus must be fitted:
 - (a) at the same height; and
 - (b) as high as practicable; and
 - (c) with the lowest point on the lens of each light not lower than midway between the highest and lowest points on the bus body.
- (5) If the centres of the warning lights are under 1.8 metres above ground level, no part of the warning lights or warning sign may be on the left of the bus.
- (6) This rule applies to a bus despite any requirement of a third edition ADR.

112 Operation and performance of warning lights

- (1) When operating, a warning light must display regular flashes of yellow light at a rate of at least 90, and not over 180, flashes a minute.

[r 113]

- (2) The warning lights at the same end of the bus must flash alternately.
- (3) Unless the driver has turned the warning lights off, they must operate automatically when a door on the bus opens and for at least 10, and not over 20, seconds after all the doors on the bus have closed.
- (4) The bus must have a visible or audible signal that tells the driver when the warning lights are operating.
- (5) The bus must be fitted with a switch that allows the driver to turn the warning lights off.
- (6) A warning light must have:
 - (a) an effective lit lens area of at least 60 square centimetres; and
 - (b) a luminous intensity (in candela) of at least the values mentioned in the following table when measured at the angles mentioned in the table.

Vertical angle from centre of light	Horizontal angle from centre of light								
	-30°	-20°	-10°	-5°	0°	5°	10°	20°	30°
10°				50	80	50			
5°		180	320	350	450	350	320	180	
0°	75	450	1000	1250	1500	1250	1000	450	75
-5°	40	270	450	570	600	570	450	270	40
-10°				75	75	75			

- (7) For subrule (6) (b), the luminous intensity of a light is to be measured in accordance with the test method mentioned in third edition ADR 6.

113 Specifications for warning signs

- (1) A warning sign at the front of the bus must:
 - (a) display the words 'school bus' in capital letters at least 100 millimetres high; or
 - (b) display an image of 2 children in the same proportions as the children in AS 1743 *Road Signs — Specifications* (image W6-3), with the image of the taller child at least 230 millimetres high.
- (2) A warning sign at the rear of the bus must display an image of 2 children in the same proportions as the children in AS 1743 *Road Signs — Specifications* (image W6-3), with the image of the taller child at least 230 millimetres high.
- (3) The warning sign mentioned in subrules (1) (b) and (2) must:
 - (a) be a rectangular shape at least:
 - (i) if warning lights are on the warning sign — 550 millimetres wide and 400 millimetres high; and

[r 113]

- (ii) in any other case — 400 millimetres wide and 250 millimetres high; and
- (b) have a black border; and
- (c) have black graphics and be coated with yellow retro-reflective material of class 1 or 2 that meets Australian Standard AS 1906 *Retro-reflective Materials and Devices for Road Traffic Control Purposes*.

Division 20 Other lights, reflectors, rear marking plates or signals

114 Other lights and reflectors

- (1) In this rule:

dimension exemption means an exemption from a dimension requirement for a vehicle as required by the Light Vehicle Standards or another law of this jurisdiction.

special use vehicle means any of the following vehicles:

- (a) a vehicle built or fitted for use in hazardous situations on a road;
- (b) a vehicle used on a road under a dimension exemption;
- (c) a vehicle built or fitted to accompany a vehicle mentioned in paragraph (b);
- (d) a vehicle that is a bus fitted, before July 1999, with a sign telling road users that the bus carries children.

- (2) An exempt vehicle may be fitted with any light or reflector.

- (3) A special use vehicle may be fitted with 1 or more flashing yellow lights.

Examples of special use vehicles to which subrule (3) applies:

- Tow trucks
- Vehicle breakdown service vehicles

- (4) A vehicle may not be fitted with any light or reflector not permitted under the Light Vehicle Standards other than a light or reflector required or permitted by another law of this jurisdiction.

- (5) A vehicle, other than an exempt vehicle or a special use vehicle, must not be fitted with a light that flashes other than as required or permitted by another law of this jurisdiction.

- (6) A vehicle, other than an exempt vehicle, must not be fitted with a light or reflector that:

- (a) shows a red light to the front; or
- (b) shows a white light to the rear; or
- (c) is shaped or located in a way that reduces the effectiveness of another light or reflector required to be fitted to the vehicle under the Light Vehicle Standards.

- (7) Any requirements in a third edition ADR that are inconsistent with subrule (2) do not apply to an exempt vehicle.

[r 115]

- (8) Any requirements in a third edition ADR that are inconsistent with subrule (3) do not apply to a special use vehicle.

115 Rear marking plates and conspicuity markings

- (1) In this rule:

conspicuity marking means a conspicuity marking within the meaning of ADR 13/00.

rear marking plate means a rear marking plate that complies with the Vehicle Standards Bulletin titled ‘VSB 12—National Code of Practice—Rear Marking Plates’.

Note The Vehicle Standards Bulletin titled ‘VSB 12—National Code of Practice—Rear Marking Plates’ is available from the National Heavy Vehicle Regulator’s website at www.nhvr.gov.au.

- (2) Rear marking plates or conspicuity markings may be fitted to:
- (a) a motor vehicle; or
 - (b) a trailer.

Note See also the Vehicle Standards Bulletin titled ‘VSB 12—National Code of Practice—Rear Marking Plates’ for requirements about ‘Do not overtake turning vehicle’ signs that may apply to a vehicle fitted with conspicuity markings.

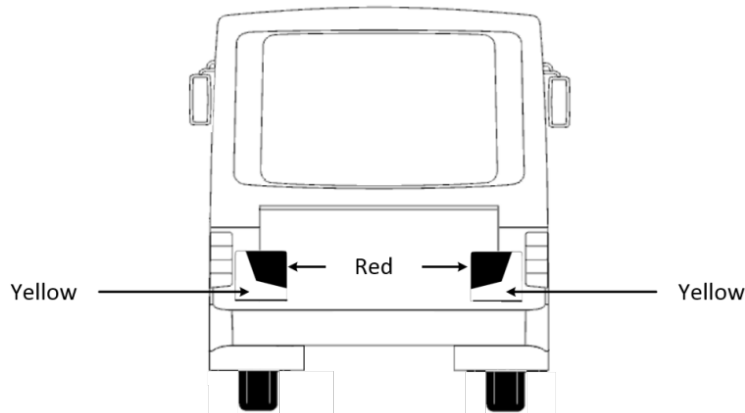

An example of rear marking plates

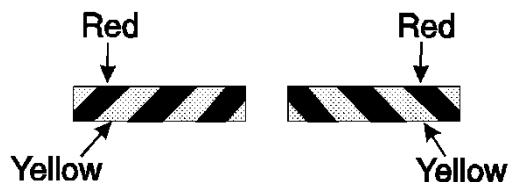

An alternative pattern for rear marking plates

116 Signalling devices

- (1) This rule applies to a motor vehicle if:
 - (a) the vehicle is not fitted with a brake light or direction indicator light mentioned in Division 10 or 12; and
 - (b) the construction of the vehicle would otherwise prevent the driver from hand signalling an intention:
 - (i) to turn or move the vehicle to the right; or
 - (ii) to stop or suddenly reduce the speed of the vehicle.
- (2) The vehicle must be fitted with a mechanical signalling device or a pair of turn signals.

117 Mechanical signalling devices

- (1) A mechanical signalling device must:
 - (a) be fitted to the right side of the vehicle; and
 - (b) be able to be operated by the driver from a normal driving position; and
 - (c) consist of a white or yellow representation of an open human hand at least 15 centimetres long; and
 - (d) be constructed so that the driver of the vehicle can keep the device:
 - (i) in a neutral position so it is unlikely that the driver of another vehicle or anyone else would regard it as a signal; and
 - (ii) in a horizontal position with the palm of the hand facing forwards and the fingers pointing out at a right angle to the vehicle to signal an intention to turn or move right; and
 - (iii) with the palm of the hand facing forwards and the fingers pointing upwards to signal an intention to stop or reduce speed suddenly.
- (2) When the mechanical signalling device is in a position mentioned in subrule (1) (d) (ii) or (iii), the complete hand must be clearly visible from both the front and the rear of the vehicle, at a distance of 30 metres.

118 Turn signals

A turn signal must:

- (a) consist of a steady or flashing illuminated yellow sign at least 15 centimetres long and 25 millimetres wide that:
 - (i) when in operation — is kept horizontal; and

[r 118]

- (ii) when not in operation — is kept in a position so it is unlikely that the driver of another vehicle or anyone else would regard it as a signal; and
- (b) be fitted to the side of the motor vehicle at least 50 centimetres and not over 2.1 metres above ground level, in a position so the driver of the vehicle, from the normal driving position, can see whether the signal is in operation; and
- (c) be able to be operated by the driver from the normal driving position; and
- (d) when in operation, be visible from both the front and rear of the vehicle at a distance of 30 metres.

Part 8 Braking systems

Note This Part sets out the braking system requirements for vehicles to ensure that they can be reliably slowed or stopped even if a part of a braking system fails, and to ensure that a vehicle can be prevented from rolling away when parked.

Division 1 Brake requirements for all vehicles

119 Components of a braking system

A brake tube or hose fitted to a vehicle must:

- (a) be manufactured from a material appropriate to the tube's or hose's intended use in the vehicle; and
- (b) be long enough to allow for the full range of steering and suspension movements of the vehicle; and
- (c) be fitted to prevent the tube or hose being damaged during the operation of the vehicle by:
 - (i) a source of heat; or
 - (ii) any movement of the parts to which the tube or hose is attached or near.

120 Provision for wear

The braking system of a vehicle must allow for adjustment to take account of normal wear.

121 Supply of air or vacuum to brakes

- (1) In this rule:

air brake compressor, of a vehicle, means a compressor for supplying air to the vehicle's air brakes.

compressed air reserve, for a vehicle, means compressed air stored on the vehicle for supplying the vehicle's braking system.

condensate drain valve means a device used to remove water from the compressed air reserve for a vehicle fitted with air brakes.

governor cut-out pressure, of a vehicle, means the air pressure at which the vehicle's air brake compressor stops supplying air to the vehicle's air brake reservoir.

spring brake means a brake using 1 or more springs to store the energy needed to operate the brake.

vacuum reserve, in relation to a vehicle, means air at a low pressure stored on the vehicle for supplying the vehicle's braking system.

[r 122]

- (2) If air brakes are fitted to a vehicle:
 - (a) the vehicle's air brake compressor must be able to build up air pressure to at least 80% of the vehicle's governor cut-out pressure, in not more than 5 minutes after the compressed air reserve is fully used up; and
 - (b) there must be an automatic or manual condensate drain valve at the lowest point of each air brake reservoir in the vehicle's braking system; and
 - (c) any spring brake fitted to the vehicle must not operate before the warning mentioned in rule 128 (3) (a) has been given.
- (3) If vacuum brakes are fitted to a vehicle, the vacuum supply must be able to build up vacuum:
 - (a) to the level when the warning signal mentioned in rule 128 (3) (a) no longer operates within 30 seconds after the vacuum reserve is fully used up; and
 - (b) to the normal working level within 60 seconds after the vacuum reserve is fully used up.

122 Performance of braking systems

- (1) One sustained application of the brake of a motor vehicle built after 1930, or a combination that includes a motor vehicle built after 1930, must be able to produce the performance mentioned in subrules (2) to (7):
 - (a) when the vehicle or combination is on a dry, smooth, level road surface, free from loose material; and
 - (b) whether or not the vehicle or combination is loaded; and
 - (c) without part of the vehicle or combination moving outside a straight path:
 - (i) centred on the longitudinal axis of the vehicle or combination before the brake was applied; and
 - (ii) 3.7 metres wide.
- (2) The braking system of a motor vehicle or combination with a gross mass under 2.5 tonnes must bring the vehicle or combination from a speed of 35 kilometres an hour to a stop within:
 - (a) 12.5 metres when the service brake is applied; and
 - (b) 30 metres when the emergency brake is applied.
- (3) The braking system of a motor vehicle or combination with a gross mass of at least 2.5 tonnes must bring the vehicle or combination from a speed of 35 kilometres an hour to a stop within:
 - (a) 16.5 metres when the service brake is applied; and

[r 122]

- (b) 40.5 metres when the emergency brake is applied.
- (4) The braking system of a motor vehicle or combination with a gross mass under 2.5 tonnes must decelerate the vehicle or combination, from any speed at which the vehicle or combination can travel, by an average of at least:
 - (a) 3.8 metres a second a second when the service brake is applied; and
 - (b) 1.6 metres a second a second when the emergency brake is applied.
- (5) The braking system of a motor vehicle or combination with a gross mass of at least 2.5 tonnes must decelerate the vehicle or combination, from any speed at which the vehicle or combination can travel, by an average of at least:
 - (a) 2.8 metres a second a second when the service brake is applied; and
 - (b) 1.1 metres a second a second when the emergency brake is applied.
- (6) The braking system of a motor vehicle or combination with a gross mass under 2.5 tonnes must achieve a peak deceleration of the vehicle or combination, from any speed at which the vehicle or combination can travel, of at least:
 - (a) 5.8 metres a second a second when the service brake is applied; and
 - (b) 1.9 metres a second a second when the emergency brake is applied.
- (7) The braking system of a motor vehicle or combination with a gross mass of at least 2.5 tonnes must achieve a peak deceleration of the vehicle or combination, from any speed at which the vehicle or combination can travel, of at least:
 - (a) 4.4 metres a second a second when the service brake is applied; and
 - (b) 1.5 metres a second a second when the emergency brake is applied.
- (8) The parking brake of a vehicle or combination must be able to hold the vehicle or combination stationary on a 12% gradient:
 - (a) when the vehicle or combination is on a dry, smooth road surface, free from loose material; and
 - (b) whether or not the vehicle or combination is loaded.

Division 2 Motor vehicle braking systems

123 What braking system a motor vehicle must have

- (1) In this rule:

independent brake, for a vehicle, means a brake that is operated entirely separately from any other brake on the vehicle, except for any drum, disc or part, on which a shoe, band or friction pad makes contact, that is common to 2 or more brakes.
- (2) A motor vehicle with 4 or more wheels built, or used, mainly for transporting goods or people by road must be fitted with:
 - (a) a braking system that:
 - (i) consists of brakes fitted to all wheels of the vehicle; and
 - (ii) has at least 2 separate methods of activation, arranged so effective braking remains on at least 2 wheels if a method fails; or
 - (b) 2 independent brakes, each of which, when in operation, acts directly on at least half the number of wheels of the vehicle.
- (3) The braking system of a motor vehicle mentioned in subrule (2) that was built after 1945 must have a service brake operating on all wheels that, when applied:
 - (a) acts directly on the wheels and not through the vehicle's transmission; or
 - (b) acts on a shaft between a differential of the vehicle and a wheel.
- (4) The braking system of a motor vehicle with 4 or more wheels must have a parking brake that:
 - (a) is held in the applied position by direct mechanical action without the intervention of an electrical, hydraulic or pneumatic device; and
 - (b) is fitted with a locking device that can hold the brake in the applied position; and
 - (c) has its own separate control.
- (5) The parking brake may also be the emergency brake.
- (6) If 2 or more independent brakes are fitted to a motor vehicle with 4 or more wheels, the brakes must be arranged so brakes are applied to all the wheels on at least 1 axle of the vehicle when any brake is operated.
- (7) A motor bike or motor trike must be fitted with:
 - (a) 2 independent brakes; or

[r 124]

- (b) a single brake that acts directly on all wheels of the vehicle and is arranged so effective braking remains on at least 1 wheel if a part of the system fails.
- (8) Subrule (7) applies to a motor bike with a sidecar attached as if the sidecar were not attached.
- (9) A motor trike must have a parking brake that is held in the applied position by mechanical means.

124 Operation of brakes on motor vehicles

The braking system on a motor vehicle must be arranged to allow the driver of the motor vehicle to apply the brakes from a normal driving position.

125 Air or vacuum brakes on motor vehicles

- (1) If a motor vehicle has air brakes, the braking system of the vehicle must include at least 1 air storage tank.
- (2) If a motor vehicle has vacuum brakes, the braking system of the vehicle must include at least 1 vacuum storage tank.
- (3) An air or vacuum storage tank must be built so the service brake can be applied to meet the performance standards of rule 122 at least twice if the engine of the vehicle stops or the source of air or vacuum fails.
- (4) An air or vacuum storage system must be safeguarded by a check valve or other device against loss of air or vacuum if the supply fails or leaks.

Division 3 Trailer braking systems

126 What brakes a trailer must have

- (1) A trailer with a GTM over 750 kilograms must have brakes that operate on at least 1 wheel at each end of 1 or more axles of the trailer.
- (2) A semi-trailer or converter dolly with a GTM over 2 tonnes must have brakes that operate on all its wheels.

127 Operation of brakes on trailers

- (1) The braking system of a trailer with a GTM over 2 tonnes must allow the driver of a motor vehicle towing the trailer to operate the brakes from a normal driving position.
- (2) The brakes on a trailer with a GTM over 2 tonnes must:
 - (a) operate automatically and quickly if the trailer breaks away from the towing vehicle; and
 - (b) remain in operation for at least 15 minutes after a break-away; and
 - (c) be able to hold the trailer on a 12% grade while in operation after a break-away.

128 Air or vacuum brakes on trailers

- (1) If a trailer has air brakes, its braking system must include at least 1 air storage tank.
- (2) If a trailer has vacuum brakes, its braking system must include at least 1 vacuum storage tank.
- (3) An air or vacuum storage system must:
 - (a) be built to give a visible or audible warning to the driver of the towing vehicle, while in a normal driving position, of a lack of air or vacuum that would prevent the brakes from meeting the performance standards of rule 122; and
 - (b) be safeguarded by a check valve or other device against loss of air or vacuum if the supply fails or leaks.
- (4) Subrules (1), (2) and (3) do not apply to a trailer with a GTM of 2 tonnes or less.

Part 9 Control of emissions

Note This Part sets out requirements to ensure that motor vehicles do not emit too much smoke or noise and that exhaust gases cannot enter the passenger compartment of a vehicle.

Division 1 Crank case gases and exhaust emissions

129 Crank case gases

- (1) This rule applies to a motor vehicle with 4 or more wheels that is powered by a petrol engine and was built after 1971.
- (2) The vehicle must be built to prevent, or fitted with equipment that prevents, crank case gases from escaping to the atmosphere.

130 Visible emissions – vehicles with internal combustion engines

- (1) This rule applies to a motor vehicle that is propelled by an internal combustion engine and was built after 1930.
- (2) The vehicle must not emit visible emissions for a continuous period of at least 10 seconds.
- (3) However, this rule does not apply to emissions that are visible only because of heat or the condensation of water vapour.

131 Exhaust emissions – diesel-powered vehicles

- (1) In this rule:
GCM (gross combination mass), of a motor vehicle, means the greatest possible sum of the maximum loaded mass of the motor vehicle and any vehicle or vehicles that may be towed by the motor vehicle at the same time:
 - (a) as stated on the RAV for that vehicle; or
 - (b) if it is not stated on the RAV — as stated by the vehicle's manufacturer on an identification plate on the vehicle (that is, the plate of the kind referred to in section 10A of the Motor Vehicle Standards Act, affixed or taken to be affixed to the vehicle, in force immediately before the repeal of that Act); or
 - (c) if it is not stated on the RAV or on the vehicle's identification plate, or if there is a specification on an identification plate on the vehicle but the specification is not appropriate because the vehicle has been modified — as certified by the vehicle registration authority.

[r 131]

oxides emission rate means the rate measured in grams of NO_x emitted per kilometre travelled per tonne of the vehicle's test mass.

particle emissions rate means the rate measured in grams of particles emitted per kilometre travelled per tonne of the vehicle's test mass.

tare mass of a vehicle means the vehicle's unladen mass (however described).

vehicle's test mass means:

- (a) if the vehicle is a prime mover — half the sum of its tare mass and its GCM; or
- (b) in any other case — half the sum of its tare mass and its GVM.

Note The **vehicle's test mass** is the load applied to the dynamometer, while the vehicle is under test, to simulate half payload operation.

- (2) This rule applies to a motor vehicle:
 - (a) powered by a diesel engine; and
 - (b) meeting the criteria for a passenger vehicle including omnibuses and goods vehicles as defined under the ADRs.
- (3) For subrule (4), a vehicle is taken to have been manufactured:
 - (a) if the vehicle is entered on the RAV — in the month stated as the month of manufacture on the RAV for the vehicle; or
 - (b) if the vehicle is not entered on the RAV — in the month shown on its identification plate (that is, the plate of the kind referred to in section 10A of the Motor Vehicle Standards Act approved to be affixed on the vehicle before the repeal of that Act) as its month of manufacture.
- (4) When a vehicle is tested in accordance with the procedure described in rule 133:
 - (a) the vehicle must not emit oxides of nitrogen (NO_x) at an oxides emission rate greater than that stated for the vehicle according to its GVM rating and age in the following table; and

vehicle's GVM rating (t)	oxides emission rate (g/km/t)	
	<i>Vehicle manufactured in December 1995 or earlier</i>	<i>Vehicle manufactured in January 1996 or later</i>
3.5 or less	1.5	1.5
More than 3.5	2.0	2.0

[r 132]

- (b) the vehicle must not emit particles at a particle emissions rate greater than that stated for the vehicle according to its GVM rating and age in the following table; and

vehicle's GVM rating (t)	particle emissions rate (g/km/t)	
	<i>Vehicle manufactured in December 1995 or earlier</i>	<i>Vehicle manufactured in January 1996 or later</i>
3.5 or less	0.23	0.23
More than 3.5	0.23	0.15

- (c) the opacity of the exhaust gas emitted by the vehicle must not be greater than 25%, averaged over a DT 80 test cycle in the way described or mentioned in the test procedure stated in rule 133, that complies with rule 132.

132 Requirements of DT 80 test cycle

- (1) The requirements stated in the following subrules are the minimum standards for the dynamometer, emissions measurement and data management systems necessary to enable the proper conduct of the DT 80 test cycle mentioned in rule 131 (4) (c).
- (2) The DT 80 test cycle must be conducted on a chassis dynamometer system that:
 - (a) can carry out a full throttle transient DT 80 test cycle, as described in rule 133, for the vehicle being tested; and
 - (b) provides for vehicle speed measurement and display, to an accuracy of $\pm 1\%$ of actual speed; and
 - (c) provides internal steady state accuracy of $\pm 1\%$ of calculated required tractive load over ambient temperatures of 2° – 40° C; and
 - (d) provides a T95 response time of 3 seconds or less; and
 - (e) provides inertial loading as required by the DT 80 protocol at speeds >15 km/h; and
 - (f) compensates for aerodynamic drag, rolling resistance and other parasitic losses; and
 - (g) corrects for ambient temperature, humidity and air density; and
 - (h) provides torque measurement accuracy of better than 1% full scale; and
 - (i) keeps roller speed within ± 10 km/h through gear changes; and

[r 132]

- (j) restricts overshoot upon initial acceleration of rollers from rest; and
 - (k) incorporates a driver control panel for remote operation of critical functions from the driver's seat, including controls for start test and stop test; and
 - (l) incorporates an emergency system override function; and
 - (m) is able to communicate speed, load and status signals to enable the driver to undertake the test in accordance with the DT 80 procedure; and
 - (n) is integrated with the gas and particulate analysis system to initiate the start and finish of sampling and measurement, and generates emission results without the need for post-test processing.
- (3) The emissions measurement system used for the DT 80 test cycle must:
- (a) be integrated with the dynamometer system stated in subrule (2); and
 - (b) have a data averaging interval of 1 second for all equipment; and
 - (c) provide emissions data sampling output $\geq 5\text{Hz}$; and
 - (d) measure oxides of nitrogen (from a diluted and conditioned sample) with an accuracy of $\pm 30\text{ppm}$ over the range 0-1000ppm and $\pm 5\%$ over the range 1001-5000ppm; and
 - (e) measure particulate matter (from diluted sample) as TSP or PM 10 with an accuracy of $\pm 10\%$ on a real time continuous basis over a range of 0-1000 mg/m^3 actual exhaust concentration at a sample temperature of $<51.7^\circ\text{C}$; and
 - (f) measure opacity (from a raw exhaust gas sample) with an accuracy of $\pm 1\%$ over a range of 0-100% opacity; and
 - (g) measure flow rate with an accuracy of $\pm 5\%$; and
 - (h) measure ambient temperature with an accuracy of $\pm 1^\circ\text{C}$ over a range of 0 – 50 $^\circ\text{C}$; and
 - (i) measure ambient humidity with an accuracy of $\pm 5\%$ over a range of 0-100%; and
 - (j) compensate or correct for ambient humidity and temperature; and
 - (k) compensate for exhaust gas transport times and delays; and
 - (l) provide on-line calibration of the analytical system; and
 - (m) provide an exhaust sample collection and conditioning system:
 - (i) that is optimised to accommodate the exhaust temperature and flow rate, and emission concentration, for the vehicle being tested; and

[r 132]

- (ii) that provides adequate conditioning of the exhaust gas to eliminate water in the sample stream and reduce temperatures to enable PM to be sampled at $< 51.7^{\circ}\text{C}$; and
 - (n) use materials and equipment compatible with the exhaust from diesel-fuelled vehicles.
- (4) The data management system used for the DT 80 test cycle must:
 - (a) be integrated with the dynamometer and emissions measurement systems stated in subrules (2) and (3); and
 - (b) record the following items for each test:
 - (i) date, time, location and operator;
 - (ii) emissions analyser calibration data;
 - (iii) vehicle input data, including test mass tractive load corrections and identifying information;
 - (iv) dynamometer data (load, speed, distance) on a second by second basis;
 - (v) test data on a second by second basis from which a mass emission test result in g/km/t can be generated; and
 - (c) display, store and report all data in the International System of units (SI units); and
 - (d) provide a system for electronic backup of test data to local and remote media; and
 - (e) incorporate a quality control system that:
 - (i) ensures calibrations are carried out in accordance with manufacturers' specifications; and
 - (ii) provides records consistent with normal audit requirements; and
 - (f) print a test report containing at least the following items:
 - (i) registered business name, ABN and address of the test facility;
 - (ii) registration number, make, model, GVM rating and date of manufacture of the tested vehicle;
 - (iii) date and location of test;
 - (iv) the final calculated NO_x and PM results in g/km/t;
 - (v) the final calculated opacity results in per cent;
 - (vi) a statement of pass or fail for each emission compared to the emission limits stated in rule 131;

- (vii) the signature of the test facility operator confirming that the test was conducted in accordance with the test procedure described in rule 133 and the requirements of this rule.

133 Test procedure

For the purposes of rule 131 (4), the procedure for testing is as follows.

- Step 1** Secure the vehicle on the dynamometer.
- Step 2** Set the dynamometer to simulate the correct load and inertia for the vehicle.
- Step 3** Start sampling.
- Step 4** Idle for 60 seconds.
- Step 5** Accelerate rapidly to 80 km/h under simulated inertia, using wide open throttle, making gear changes as needed for smooth acceleration.
- Step 6** Decelerate by removing all pressure from the accelerator pedal, disengaging the gears and gently applying brakes to bring the vehicle to a standstill.
- Step 7** Idle for 10 seconds.
- Step 8** Accelerate rapidly to 80 km/h under simulated inertia, using wide open throttle, making gear changes as needed for smooth acceleration.
- Step 9** Decelerate by removing all pressure from the accelerator pedal, disengaging the gears and gently applying brakes to bring the vehicle to a standstill.
- Step 10** Idle for 10 seconds.
- Step 11** Accelerate rapidly to 80 km/h under simulated inertia, using wide open throttle, making gear changes as needed for smooth acceleration.
- Step 12** Keep speed at 80 km/h for 60 seconds, then stop sampling and bring the vehicle to rest.

Note Explanation of the test procedure

This test has been designed to evaluate vehicle emissions during typical 'real-world' operating modes and conditions. There are 3 simple modes:

- 3 idle periods
- acceleration to 80 km/h 3 times
- keep speed at 80 km/h.

The graph below shows the modes of operation. The actual test will result in a graph that has more variation than the graph below, because of the need to change gears when accelerating. Modes B–D and E–G and H–I have no specific time interval. All the specified time periods have an error margin of ± 1 second.

The vehicle is accelerated rapidly to 80 km/h 3 times by applying wide open throttle.

[r 133]

The driver selects the most appropriate gear change points for the vehicle being tested to achieve the correct speed.

The vehicle's rolling resistance (based on tyre and bearing losses, frontal area and drag coefficient) must also be calculated and continuously factored into the dynamometer tractive effort calculations to ensure correct loading.

Empirical algorithms, based on vehicle test mass, GVM or other known parameters, may be used to automatically calculate realistic coefficients for the variables.

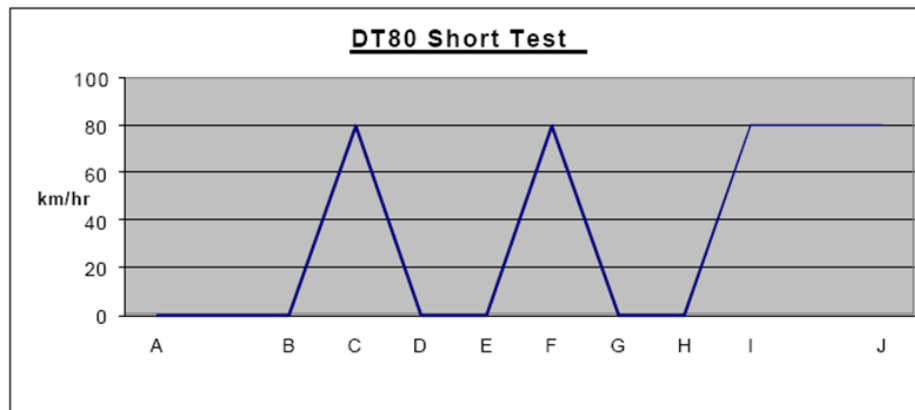

Division 2 Exhaust systems

134 Exhaust systems

- (1) In this rule:

vertical exhaust system means an exhaust system that emits exhaust gases in an upward direction above or near the top of a vehicle to which the exhaust system is fitted.
- (2) An outlet (a *motor trike exhaust outlet*) of an exhaust system fitted to a motor trike with a permanently enclosed body must extend:
 - (a) at least 40 millimetres beyond the outermost joint of the floorpan that is not continuously welded or permanently sealed; and
 - (b) not beyond the perimeter of the vehicle.
- (3) The motor trike exhaust outlet must discharge the main exhaust flow to the air:
 - (a) if the outlet is fitted to the side of the motor trike — to the right hand side of the motor trike and below the horizontal axis of the motor trike at an angle between 15 degrees and 45 degrees; or
 - (b) if the outlet is fitted to the rear of the motor trike — at an angle between 10 degrees above the horizontal axis of the motor trike and 45 degrees below that axis.
- (4) An outlet (a *bus exhaust outlet*) of an exhaust system fitted to a bus must be as near as practicable to the rear of the bus.
- (5) If the bus is not fitted with a vertical exhaust system, the bus exhaust outlet must not extend beyond the perimeter of the bus.
- (6) If the bus is fitted with a vertical exhaust system, the bus exhaust outlet must be located behind the rearmost part of the passenger compartment.
- (7) A bus exhaust outlet must discharge the main exhaust flow to the air:
 - (a) if the outlet is not part of a vertical exhaust system:
 - (i) towards the rear, or to the right, of the bus; and
 - (ii) horizontally or downwards at an angle not more than 45 degrees below the horizontal axis; or
 - (b) if the outlet is part of a vertical exhaust system — vertically upwards or towards the rear of the bus at any angle above the horizontal axis.

Division 3 Noise emissions

Subdivision 1 General

135 Measurement of stationary noise levels

- (1) For this Division, the stationary noise level of a motor vehicle is to be measured in accordance with the procedure set out for the kind of vehicle in the National Stationary Exhaust Noise Test Procedures for In-Service Motor Vehicles – September 2006 (ISBN: 1 921168 50 1) published by the Commission.
- (2) In subrule (1), **Commission** means the National Transport Commission established by the National Transport Commission Act 2003 of the Commonwealth.

Note The National Stationary Exhaust Noise Test Procedures for In-Service Motor Vehicles – September 2006 is available on the Commission’s web site at www.ntc.gov.au

136 Meaning of “certified to ADR83/00”

For the purposes of this Division, a vehicle is *certified to ADR 83/00* if:

- (a) immediately before the repeal of the Motor Vehicle Standards Act, approval has been given under section 10A of that Act to place an identification plate showing compliance with ADR 83/00 on the vehicle; or
- (b) an approval is given under item 4 (2) or 6 (2) of Schedule 3 to the *Road Vehicle Standards (Consequential and Transitional Provisions) Act 2018* (Cwlth); or
- (c) the vehicle has satisfied an entry pathway under section 15 (2) of the Road Vehicle Standards Act, including compliance with ADR 83/00, and the vehicle is entered on the RAV.

137 Silencing device for exhaust systems

- (1) A motor vehicle propelled by an internal combustion engine must be fitted with a silencing device through which all the exhaust from the engine passes.
- (2) For subrule (1), any silencing device designed to be manipulated by the vehicle’s operator, such as by means of in-vehicle controls, must be designed so that it can be tested with the device fully opened.

Subdivision 2 Noise levels applying to vehicles certified prior to the application of ADR 83/00

138 Application of rules in Subdivision 2

This Subdivision applies to a motor vehicle other than a vehicle certified to ADR 83/00.

139 Stationary noise levels — car-type vehicles and motor bikes and motor trikes

(1) In this rule:

car-type vehicle means:

- (a) a car; or
- (b) a utility truck, panel van, or another motor vehicle derived from a car design; or
- (c) another motor vehicle with 4 or more wheels that is built mainly to carry not over 9 people including the driver.

(2) The stationary noise level of a car-type vehicle, or motor bike or motor trike, must not exceed:

- (a) for a car-type vehicle built after 1982 — 90 dB(A); or
- (b) for another car-type vehicle — 96 dB(A); or
- (c) for a motor bike or motor trike built after February 1985 — 94 dB(A); or
- (d) for another motor bike or motor trike — 100 dB(A).

140 Stationary noise levels — other vehicles with spark ignition engines

- (1) This rule applies to a motor vehicle (except a motor vehicle to which rule 139 applies) with a spark ignition engine.
- (2) The stationary noise level of the motor vehicle must not exceed the noise level applying to the vehicle under the table.

[r 141]

Column 1 Item	Column 2 GVM (t)	Column 3 Exhaust height (mm)	Column 4 When vehicle built	Column 5 Noise level (dB(A))
1	≤ 3.5	<1500	before July 1983	92
			after June 1983	89
2	>3.5	<1500	before July 1983	98
			after June 1983	95
3	≤ 3.5	≥ 1500	before July 1983	88
			after June 1983	85
4	>3.5	≥ 1500	before July 1983	94
			after June 1983	91

141 Stationary noise levels — other vehicles with diesel engines

- (1) This rule applies to a motor vehicle (except a motor vehicle to which rule 139 applies) with a diesel engine.
- (2) The stationary noise level of the motor vehicle must not exceed the noise level applying to the vehicle under the table.

Column 1 Item	Column 2 GVM (t)	Column 3 Exhaust height (mm)	Column 4 When vehicle built	Column 5 Noise level (dB(A))
1	≤ 3.5	<1500	before July 1980	105
			after June 1980 but before July 1983	102
			after June 1983	99
2	>3.5	<1500	before July 1980	107
			after June 1980 but before July 1983	104
			after June 1983	101
3	≤ 3.5	≥ 1500	before July 1980	101

[r □]

Column 1 Item	Column 2 GVM (t)	Column 3 Exhaust height (mm)	Column 4 When vehicle built	Column 5 Noise level (dB(A))
			after June 1980 but before July 1983	98
			after June 1983	95
4	>3.5	≥1500	before July 1980	103
			after June 1980 but before July 1983	100
			after June 1983	97

Subdivision 3 Noise levels applying to vehicles certified to ADR 83/00

142 Stationary noise levels

The stationary noise level of a motor vehicle that is certified to ADR 83/00 must not exceed, by more than 5 dB(A), the noise level that is established for the motor vehicle when it is certified.

Part 10 Alternative fuel systems

Note This Part sets out requirements to ensure that LPG (Liquid Petroleum Gas) and CNG (Compressed Natural Gas) fuel systems are safely installed in motor vehicles. In the case of vehicles with an LPG system installed, there is an additional requirement to ensure that they can be identified as LPG-powered vehicles.

143 LPG-powered vehicles

- (1) An LPG system installed in a motor vehicle, and the vehicle, must comply with all relevant requirements set out in the version of Australian Standard AS 1425 that was current at the time the system was installed in the vehicle.
- (2) A motor vehicle that has an LPG system installed must have fixed conspicuously to its front and rear number plates the labels required by the version of Australian Standard AS 1425 that was current at the time the system was installed in the vehicle.
- (3) If a motor vehicle had an LPG system installed before Australian Standard AS 1425 was first published, the vehicle must have fixed conspicuously to its front and rear number plates a label:
 - (a) that is made of durable material; and
 - (b) that is at least 25 millimetres wide and 25 millimetres high; and
 - (c) that is of a reflective red that conforms with either Australian Standard AS 1743 *Road Signs* or Australian Standard AS 1906 *Retroreflective materials and devices for road traffic control purposes (Part 1: Retroreflective sheeting)*; and
 - (d) that states 'LPGAS' or 'LPG', or similar words or acronyms that have the same meaning, in capital letters at least 6 millimetres high.

144 Vehicles powered by natural gas

A natural gas system installed in a motor vehicle, and the vehicle, must comply with all relevant requirements set out in the version of Australian Standard AS 2739 that was current at the time the system was installed in the vehicle.

Examples Forms of natural gas include CNG (Compressed Natural Gas) and LNG (Liquid Natural Gas).

144A Hydrogen-powered vehicles

- (1) A hydrogen-powered vehicle built after 1 January 2019, or a vehicle modified to be a hydrogen-powered vehicle after 1 January 2019, must have fixed conspicuously to its front and rear number plates:

[r 144]

- (a) for a vehicle fitted with 1 hydrogen fuel container — a label that complies with subrule (2); or
 - (b) for a vehicle fitted with 2 or more hydrogen fuel containers — 2 labels that comply with subrule (2).
- (2) For the purposes of subrule (1), a label complies with this subrule if:
- (a) it is affixed to a plate made of metal that is at least 1 millimetre thick; and
 - (b) the label, and the plate to which it is affixed, is a regular pentagonal shape:
 - (i) each side of which is 20 millimetres long; and
 - (ii) each interior angle of which is 108°; and
 - (c) it has a yellow surface that complies with class 2 of AS 1906.1 *Retroreflective Materials and Devices for Road Traffic Control Purposes—Retroreflective Sheeting*; and
 - (d) it is marked ‘H’ in a black capital letter that is at least 10 millimetres high and has the orientation shown in the example; and
 - (e) it is fixed to the number plates so that the letter on the label is in an upright position; and
 - (f) it does not wholly or partly obscure any characters on the number plates.

Example of label for hydrogen-powered vehicle:



Note The example of the label is for illustrative purposes only and does not represent the label's actual size, dimensions or colour.

[r 144]

(3) In this rule:

hydrogen-powered vehicle means a vehicle that:

- (a) is powered by a hydrogen fuel system; and
- (b) has 1 or more hydrogen fuel containers fitted to the vehicle for the system.

144B Electric-powered vehicles

- (1) An electric-powered vehicle that is built after 1 January 2019, or a vehicle modified to be an electric-powered vehicle after 1 January 2019, must have fixed conspicuously to its front and rear number plates a label that complies with subrule (2).
- (2) For the purposes of subrule (1), a label complies with this subrule if:
 - (a) it is affixed to a plate made of metal that is at least 1 millimetre thick; and
 - (b) the label, and the plate to which it is affixed, is an equilateral triangular shape:
 - (i) each side of which is 30 millimetres in length; and
 - (ii) each interior angle of which is 60°; and
 - (c) it has a blue surface that complies with class 2 of AS 1906.1 *Retroreflective Materials and Devices for Road Traffic Control Purposes—Retroreflective Sheeting*; and
 - (d) it is marked 'EV' in white capital letters that are at least 8 millimetres high and have the orientation shown in the example; and
 - (e) it is fixed to the number plates so that the letters on the label are in an upright position; and
 - (f) it does not wholly or partly obscure any characters on the number plates.

Example of label for electric-powered vehicle:



Note The example of the label is for illustrative purposes only and does not represent the label's actual size, dimensions or colour.

- (3) However, this rule does not apply to a vehicle to which rule 144A applies even if the vehicle is fitted with an electric motor or traction motor that is used in conjunction with a hydrogen fuel system for the propulsion of the vehicle.
- (4) In this rule:

electric-powered vehicle means a vehicle that is powered by 1 or more electric motors or traction motors that:

 - (a) are the only propulsion system for the vehicle; or
 - (b) are used in conjunction with another propulsion system for the vehicle.

Part 11 Mechanical connections between vehicles

Note This Part sets out various requirements to ensure that the couplings used when operating motor vehicles and trailers in combinations are strong enough to hold them together.

145 General coupling requirements

- (1) A fifth wheel coupling, the mating parts of a coupling, a kingpin or a towbar must not be used for a load more than the manufacturer's load rating.
- (2) A kingpin must be used only with a fifth wheel coupling that has a corresponding jaw size.

Example An adaptor must not be used to fit a kingpin to a fifth wheel coupling.

- (3) The mating parts of a coupling used to connect a semi-trailer to a towing vehicle must not allow the semi-trailer to roll to an extent that makes the towing vehicle unstable.

146 Drawbar couplings

- (1) A coupling for attaching a trailer, except a semi-trailer or pole-type trailer, to a towing vehicle must be built and fitted so:
 - (a) the coupling is equipped with a positive locking mechanism; and
 - (b) the positive locking mechanism can be released regardless of the angle of the trailer to the towing vehicle.
- (2) If the trailer is in a combination and is not fitted with breakaway brakes in accordance with rule 127 (2), it must be connected to the towing vehicle by at least 1 chain, cable or other flexible device, as well as the coupling required by subrule (1).
- (3) The connection must be built and fitted so:
 - (a) the trailer is kept in tow if the coupling breaks or accidentally detaches; and
 - (b) normal angular movement of the coupling is permitted without unnecessary slack.
- (4) If practicable, the connection must be built and fitted so the drawbar of the trailer is prevented from hitting the ground if the coupling accidentally detaches.
- (5) For the purposes of subrules (3) and (4), a connection between a trailer and a towing vehicle includes anything which connects the trailer and the towing vehicle.

[r 146]

Examples of what is included in a connection:

- chains
- cables
- a thing fixed to a trailer or a towing vehicle to which a chain is attached
- shackles.